



**PRONAR Sp. z o.o.**

17-210 NAREW, UL. MICKIEWICZA 101A, WOJ. PODLASKIE

tel.:	+48 085 681 63 29	+48 085 681 64 29
	+48 085 681 63 81	+48 085 681 63 82
fax:	+48 085 681 63 83	+48 085 682 71 10

[www.pronar.pl](http://www.pronar.pl)

# **OPERATOR'S MANUAL**

## **DISC MOWER**

**PRONAR PDT260, PRONAR PDT260C**

**PRONAR PDT300, PRONAR PDT300C**

**PRONAR PDT340**

TRANSLATION OF THE ORIGINAL INSTRUCTIONS

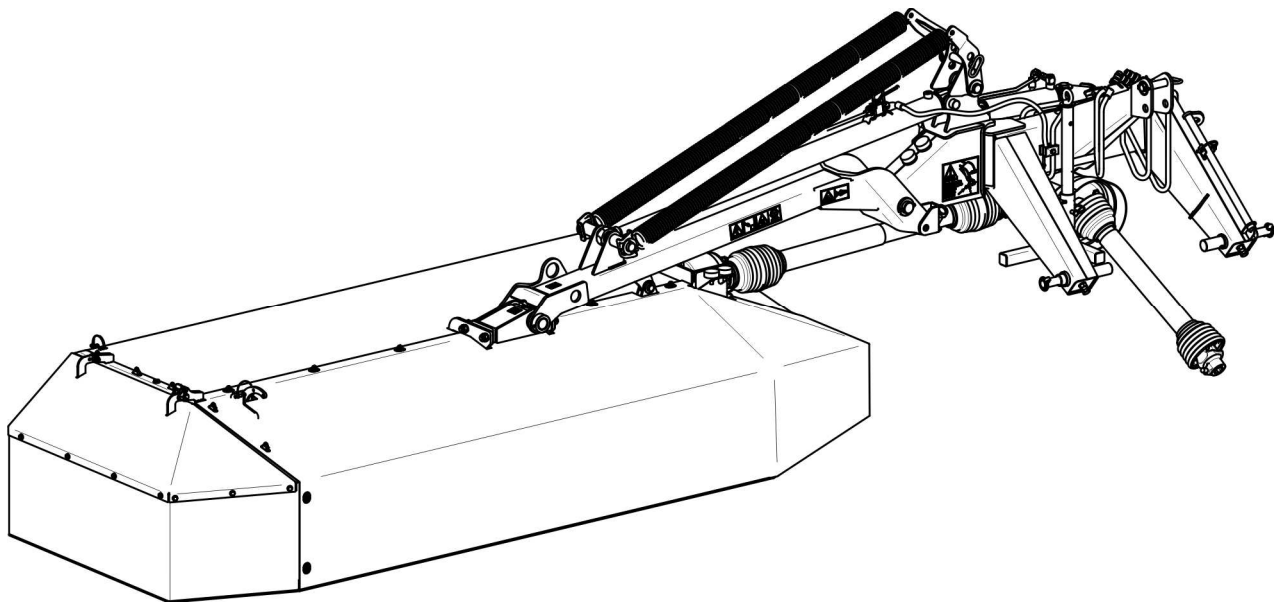

ISSUE 2B-04-2012

PUBLICATION NO 284N-00000000-UM





# DISC MOWER

**PRONAR PDT260, PRONAR PDT260C**

**PRONAR PDT300, PRONAR PDT300C**

**PRONAR PDT340**

## MACHINE IDENTIFICATION

**SYMBOL /TYPE: PDT260, PDT 260C, PDT300, PD300C, PDT340**

**SERIAL NUMBER:**

--	--	--	--	--	--	--

# INTRODUCTION

Information contained herein is current at date of publication. As a result of improvements, some numerical values and illustrations contained in this publication may not correspond to the factual specification of the machine supplied to the user. The manufacturer reserves the right to introduce design changes in machines produced that facilitate operation and improve the quality of their work, without making minor amendments to this Operator's Manual. Please send your comments and proposals on the design and operation of the machine to the manufacturer. This information enables objective evaluation of the machines produced and provides indications for their further improvement.

This Operator's Manual is an integral part of the machine's documentation. Before using the machine, the user must carefully read this Operator's Manual and observe all recommendations. This guarantees safe operation and ensures malfunction free work of the machine. The machine is designed to meet obligatory standards, documents and legal regulations currently in force.

The manual describes the basic safety rules and operation of the implement. If the information contained in the Operator's Manual needs clarification then the user should refer for assistance to the sale point where the machine was purchased or to the manufacturer.

## **MANUFACTURER'S ADDRESS:**

*PRONAR Sp. z o.o.  
ul. Mickiewicza 101A  
17-210 Narew*

## **CONTACT TELEPHONES**

<i>+48 085 681 63 29</i>	<i>+48 085 681 64 29</i>
<i>+48 085 681 63 81</i>	<i>+48 085 681 63 82</i>

Information, descriptions of danger and precautions and also recommendations and orders associated with user safety instructions are marked:



and also preceded by the word "**DANGER**". Failure to observe the instructions may endanger the machine operator's or other person's health or life.

Particularly important information and instructions, the observance of which is essential, are distinguished in the text by the sign:



and also preceded either word "**ATTENTION**". Failure to observe the instructions may lead to damage to the machine as a result of improper operation, adjustment or use.

In order to focus the user's attention on the need to perform maintenance, the relevant section of the Operator's Manual is marked with the pictogram:







**PRONAR Sp. z o.o.**

ul. Mickiewicza 101 A  
17-210 Narew, Polska

tel./fax (+48 85) 681 63 29, 681 63 81, 681 63 82,  
681 63 84, 681 64 29

fax (+48 85) 681 63 83

http://www.pronar.pl

e-mail: pronar@pronar.pl

## EC DECLARATION OF CONFORMITY OF THE MACHINERY

PRONAR Sp. z o.o. declares with full responsibility, that the machine:

Description and identification of the machinery					
Generic denomination and function:	<b>Disc Mower</b>				
Type:	<b>PDT260</b>	<b>PDT260C</b>	<b>PDT300</b>	<b>PDT300C</b>	<b>PDT340</b>
Model:	–	–	–	–	–
Serial number:					
Commercial name:	<b>Disc Mower PRONAR PDT260</b> <b>Disc Mower PRONAR PDT260C</b> <b>Disc Mower PRONAR PDT300</b> <b>Disc Mower PRONAR PDT300C</b> <b>Disc Mower PRONAR PDT340</b>				

to which this declaration relates, fulfills all the relevant provisions of the Directive **2006/42/EC** of The European Parliament and of The Council of 17 May 2006 on machinery, and amending Directive 95/16/EC (Official Journal of the EU, L 157/24 of 09.06.2006).

The person authorized to compile the technical file is the Head of Research and Development Department at PRONAR Sp. z o.o., 17-210 Narew, ul. Mickiewicza 101A, Poland.

This declaration relates exclusively to the machinery in the state in which it was placed on the market, and excludes components which are added and/or operations carried out subsequently by the final user.

Narew, the 11 CZE. 2013

Place and date

Z-CA DYREKTORA  
d/s technicznych  
szef ds. zarządu

*Roman Omelianiuk*

Full name of the empowered person  
position, signature

# TABLE OF CONTENTS

<b>1</b>	<b>BASIC INFORMATION</b>	<b>1.1</b>
1.1	IDENTIFICATION	1.2
1.1.1	MOWER IDENTIFICATION	1.2
1.2	PROPER USE	1.3
1.3	OPTIONAL EQUIPMENT	1.5
1.4	TERMS & CONDITIONS OF WARRANTY	1.5
1.5	TRANSPORT	1.6
1.6	ENVIRONMENTAL HAZARDS	1.8
1.7	WITHDRAWAL FROM USE	1.9
<b>2</b>	<b>SAFETY ADVICE</b>	<b>2.1</b>
2.1	BASIC SAFETY RULES	2.2
2.2	DRIVING ON PUBLIC ROADS	2.6
2.3	DESCRIPTION OF MINIMAL RISK	2.7
2.4	INFORMATION AND WARNING DECALS	2.8
<b>3</b>	<b>DESIGN AND OPERATION</b>	<b>3.1</b>
3.1	TECHNICAL SPECIFICATION	3.2
3.2	GENERAL DESIGN	3.4
3.3	LINKAGE	3.5
3.4	HYDRAULIC SYSTEM	3.6
3.5	DRIVE TRANSMISSION	3.7
3.6	CUTTING UNIT	3.8
3.7	SWATH CONDITIONER UNIT (PDT260, PDT300)	3.9
<b>4</b>	<b>CORRECT USE</b>	<b>4.1</b>

4.1	PREPARING FOR WORK	4.2
4.2	CHECKING TECHNICAL CONDITION	4.4
4.3	HITCHING TO TRACTOR	4.5
4.4	TRANSPORTING THE MACHINE	4.9
4.5	SETTING AND MOWING	4.13
4.5.1	SETTING MOWER IN WORKING POSITION	4.13
4.5.2	SETTING CUTTING HEIGHT	4.14
4.5.3	CONNECTING DRIVE SHAFT	4.15
4.5.4	STAY SPRING ADJUSTMENT	4.16
4.5.5	SETTINGS SWATH WIDTH	4.18
4.5.6	SET THE SWATH WIDTH OF PDT260C AND PDT300C MOWER.	4.21
4.5.7	SET THE INTENSITY OF SWATH CONDITIONING FOR THE PDT260C AND PDT300C MOWERS	4.22
4.5.8	MOWING	4.24
4.5.9	HYDRAULIC SAFETY DEVICE	4.26
4.6	DISCONNECTING FROM TRACTOR	4.26
<b>5</b>	<b>MAINTENANCE</b>	<b>5.1</b>
5.1	CHECKING AND REPLACING CUTTING BLADES	5.2
5.1.1	INSPECTION AND REPLACEMENT OF THE CUTTER BAR BLADES	5.2
5.1.2	INSPECTION AND REPLACEMENT SWATH CONDITIONER FLAIL BLADES (PDT260C, PDT300C)	5.4
5.2	CUTTERBAR MAINTENANCE	5.6
5.3	MAINTENANCE OF DRIVE UNIT	5.9
5.4	HYDRAULIC SYSTEM OPERATION	5.12
5.5	STORAGE	5.14
5.6	LUBRICATION	5.14
5.7	CONSUMABLES	5.18
5.7.1	LUBRICANTS	5.18

5.8 TIGHTENING TORQUE FOR NUT AND BOLT CONNECTIONS	5.18
5.9 TROUBLESHOOTING	5.20

*SECTION*

**1**

---

**BASIC INFORMATION**

# 1.1 IDENTIFICATION

## 1.1.1 MOWER IDENTIFICATION

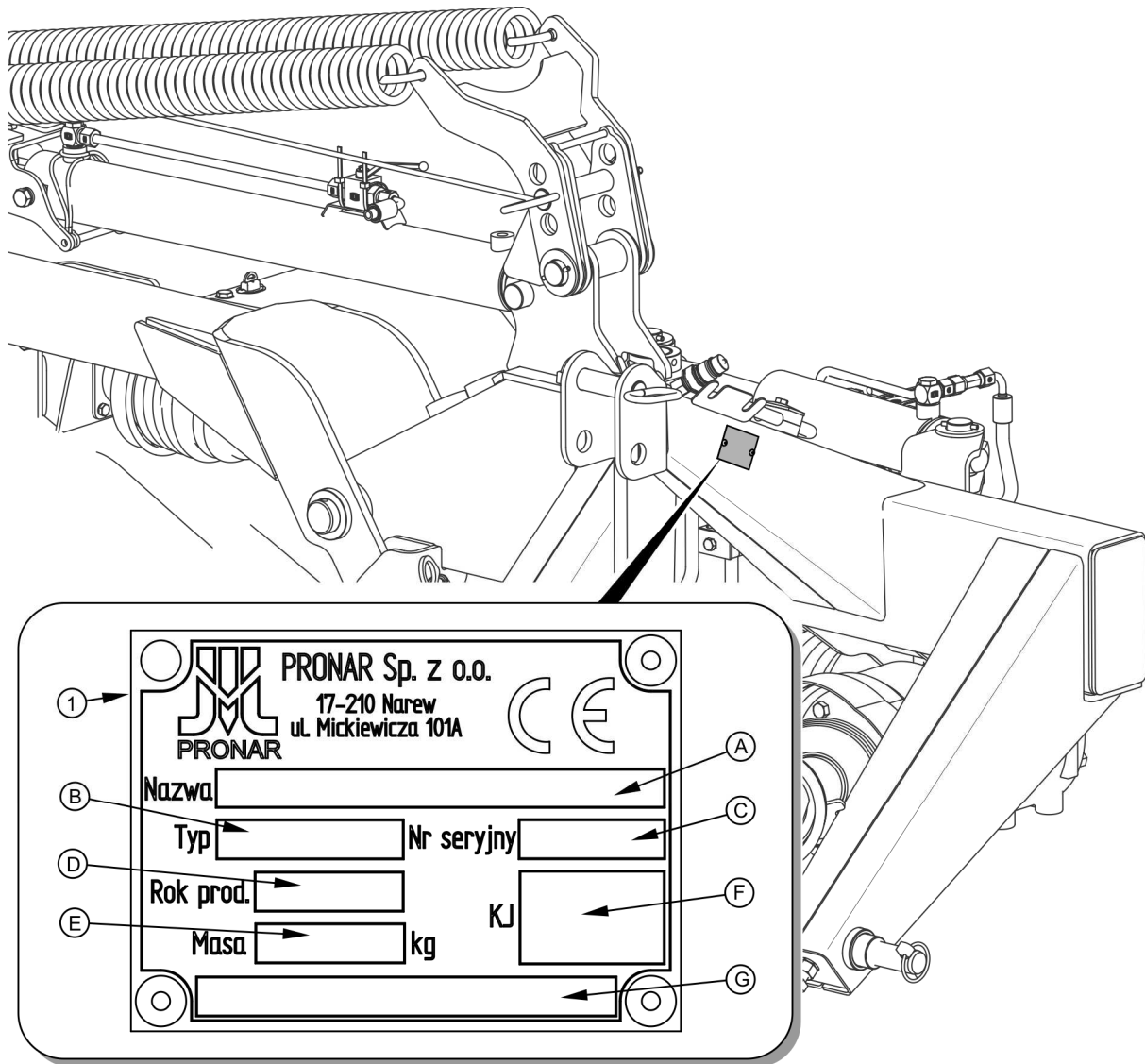

**FIG. 1.1** Location of the data plate

(1) data plate, (2) serial number

PRONAR PDT260 / PDT260C / PDT300 / PDT300C / PDT 340 mowers have data plate located on the left side, on the upper beam of the linkage frame – figure (1.1). When buying the machine, confirm that the serial number on the machine corresponds to the number indicated in the *WARRANTY BOOK*, in the sales documents and in the *OPERATOR'S*

*MANUAL*. The meanings of the individual fields found on the data plate are presented in the table below:

**TABLE 1.1 Markings on data plate**

ITEM	MARKING
A	Machine name
B	Symbol /Type
C	Serial number
D	Year of manufacture
E	Machine tare weight
F	Quality Control marking
G	Unfilled box or extension of name (box A)

## 1.2 PROPER USE

PRONAR PDT260 / PDT 260C / PDT300 / PDT300C / PDT 340 rear mounted disc mowers are constructed according to current safety requirements and engineering standards.

Pronar rear mounted disc mowers are designed to cut low stemmed green fodder (grass, lucerne, etc) on permanent grassland and on stone free cultivated fields with a level surface. Swath conditioner breaks the mown stalks and also removes layer of wax from the plant, which effectively accelerates the drying process.

Machine use for other purposes should be regarded as improper. Using it as intended also involves all actions connected with the safe and proper operation and maintenance of the machine. Due to the above, the user is obliged to:

- carefully read the *OPERATOR'S MANUAL* and comply with its recommendations,
- understand the machine's operating principle and how to operate it safely and correctly,
- comply with general safety regulations while working,
- prevent accidents,
- comply with road traffic regulations.

Unauthorized repairs and modifications of the machine without prior consent of the Manufacturer will be regarded as use contrary to the intended purpose. The machine may only be used by appropriately trained users, who are aware of the dangers, design and operation of the machine. Repairs to the machine shall only be made by qualified personnel (in the warranty period all repairs must be performed in the warranty service, indicated by the Manufacturer). Maintenance and repairs that can be performed by the user, are described in section 5 „MAINTENANCE”.

**TABLE 1.2 Agricultural tractor's requirements**

	UNIT	REQUIREMENTS
<b>Linkage</b>		
Rear three point linkage	-	Category II and III according to ISO 730
<b>Power take-off shaft</b>		
PDT 260 PTO speed	RPM	540
PDT 300 PTO speed	RPM	1,000
PDT 340 PTO speed	RPM	1,000
Number of splines on PTO shaft	item	6
PTO rotation direction	-	clockwise
<b>Hydraulic system</b>		
Nominal pressure	MPa	16
Hydraulic oil	-	HL32
Hydraulic sockets	-	3 sockets on the rear of tractor
<b>Other requirements</b>		
Minimum power		
PDT260	kW /	33 / 45
PDT260C	Horsepower	44 / 60
PDT300	kW /	44 / 60
PDT300C	Horsepower	55 / 75

PDT340	kW / Horsepower	59 / 80
--------	--------------------	---------

**IMPORTANT!**

The mower must not be used for purposes other than those for which it is intended, in particular:

- for transporting people and animals,
- for transport of whatever materials or objects.

**1.3 OPTIONAL EQUIPMENT**

EQUIPMENT	QUANTITY
Operator's Manual	1
Warranty Book	1
PTO shaft connecting tractor and mower	1

Recommended PTO shafts:

- PTO shaft connecting tractor and mower – T401010ENC12RF2,
- PTO shaft connecting intersecting axis gears of the mower – 904-01438.

**1.4 TERMS & CONDITIONS OF WARRANTY**

PRONAR Sp. z o.o., Narew guarantees the reliable operation of the machine when it is used according to its intended purpose as described in the *OPERATOR'S MANUAL*. Defects discovered during the warranty period will be removed by the Warranty Service. The repair period is specified in the *WARRANTY BOOK*.

The warranty does not apply to those parts and sub-assemblies of the machine, which are subject to wear in normal usage conditions, regardless of the warranty period. The warranty service only applies to factory defects and mechanical damage that is not due to the user's fault. Consumables include the following parts/sub-assemblies:

- cutting blades,

- protective aprons,
- bearings.

The warranty service only applies to factory defects and mechanical damage that is not due to the user's fault.

In the event of damage arising from:

- mechanical damage which is the user's fault, caused by road accidents,
- by inappropriate use, adjustment or maintenance, use of the machine for purposes other than those for which it is intended,
- use of damaged machine,
- repairs carried out by unauthorised persons, improperly carried out repairs,
- arbitrary and wilful adjustments to the machine's structure.

the user may lose the right to warranty service.

The user is obliged to report immediately on noticing any wear in the paint coating or traces of corrosion, and to have the faults rectified whether they are covered by the warranty or not. For detailed Terms & Conditions of Warranty, please refer to the *WARRANTY BOOK* attached to each machine.



### TIP

**Demand that the seller carefully and precisely fills out the Warranty Book and warranty repair coupons. A missing date of purchase or sale point stamp, may make the user ineligible for any warranty repair or refund.**

Modification of the mower without the written consent of the Manufacturer is forbidden. In particular, do NOT weld, drill holes in, cut or heat the main structural elements of the machine, which have a direct impact on the machine operation safety.

## 1.5 TRANSPORT

The machine is prepared for sale completely assembled and does not require packing. Packing is only required for the machine operator's manual and elastic covers. Supply to user takes place by transport vehicle. Transport of the mower is permissible connected to a tractor

provided the tractor's driver familiarises himself with the machine's Operator's Manual and particularly with information concerning safety and principles of connection and transport of mower on public roads. Do NOT drive the tractor with mower connected when visibility is limited.

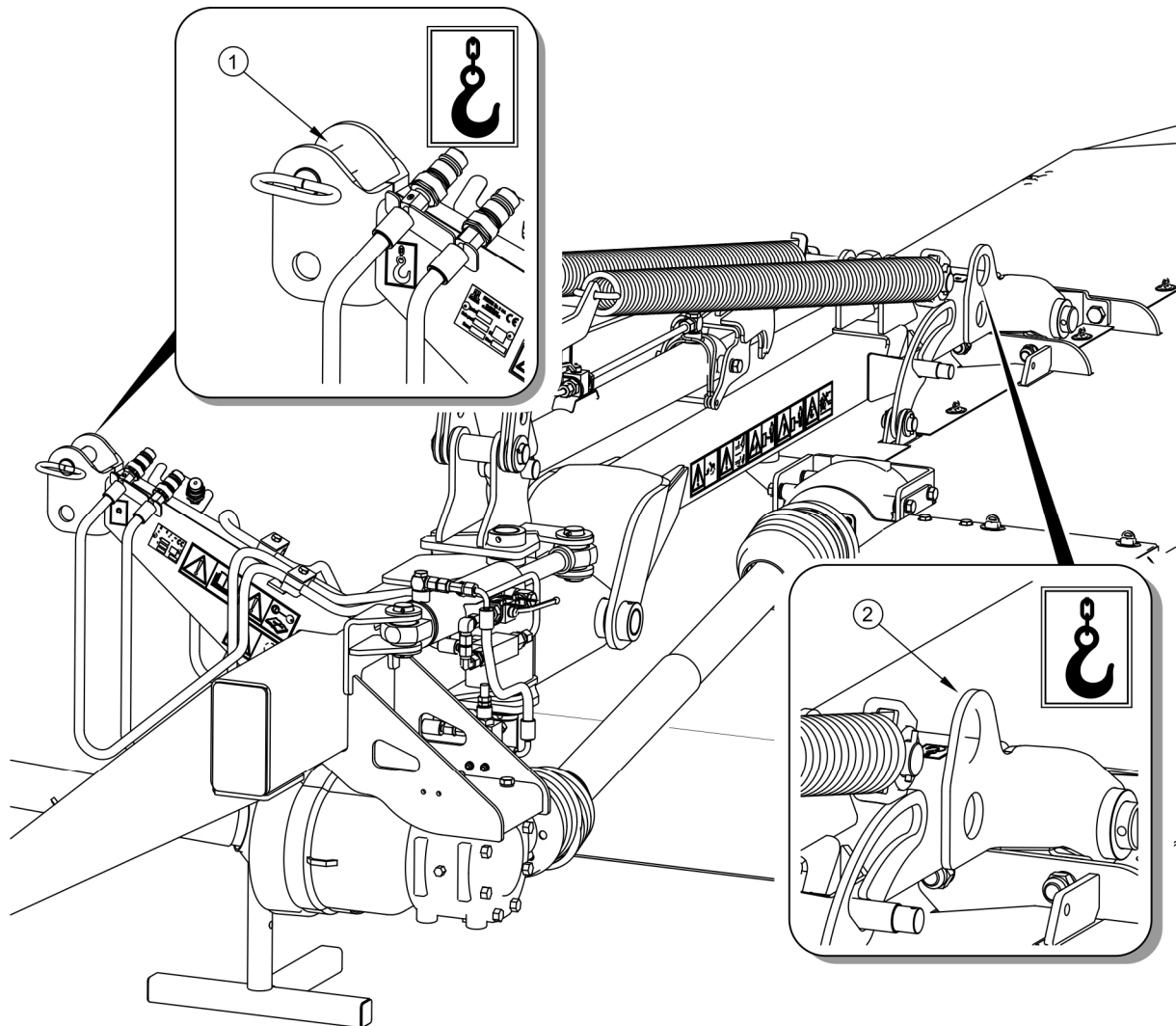

**FIG. 1.2** Transport lugs

(1) central connection pin; (2) lifting arm lug

When loading and unloading the machine, comply with the general principles of workplace health and safety for reloading work. Persons operating reloading equipment must have the qualifications required to operate these machines.

The machine should be attached to lifting equipment in places intended for this - figure (1.2), i.e. two central connection pin (1) and transport lug (2). When lifting the machine take particular care due to the possibility of tipping over the machine and the risk of injuries from

protruding parts. To keep lifted machine in the correct direction it is recommended to apply additional guy cables. During the loading work particular care should be taken not to damage paint coating. The machine should be attached firmly to the platform of the vehicle using straps or chains fitted with a tightening mechanism. The fastening equipment used must have a valid safety certificate.

## **DANGER**



When transporting independently, the user must carefully read this operator's manual and observe its recommendations. When being transported on a motor vehicle the machine must be mounted on the vehicle's platform in accordance with the transport safety requirements. The driver of the vehicle should take particular care while transporting the machine. This is due to the vehicle's centre of gravity shifting upwards when loaded with the machine.

## **IMPORTANT!**



Do NOT secure lifting slings or any types of securing elements to hydraulic cylinders.  
Do NOT stand in the manoeuvring zone during transferring mower to other form of transport.

## **DANGER**



During loading mower should be set in working position and secured. Support leg should be lowered and secured with a pin.

## **1.6 ENVIRONMENTAL HAZARDS**

A hydraulic oil leak constitutes a direct threat to the natural environment owing to its limited biodegradability. While carrying out maintenance and repair work which involves the risk of an oil leak, this work should take place on an oil resistant floor or surface. In the event of oil leaking into the environment, first of all contain the source of the leak, and then collect the leaked oil using available means. Remaining oil should be collected using sorbents, or by mixing the oil with sand, sawdust or other absorbent materials. Collected oil should be kept in sealed and clearly marked containers away from heat sources, flammable materials and

food. Oil waste should be taken to the appropriate facility dealing with the re-use of this type of waste.

It is recommended to store used oil in its original packaging.

## 1.7 WITHDRAWAL FROM USE

Before proceeding to dismantle the machine, oil shall be completely removed from hydraulic system, cutter bar, and both intersecting axis gears. Locations of drain plugs and method for draining oil are described in section 5.



### **DANGER**

**During dismantling personal protection equipment shall be used i.e. protective clothing, boots, gloves and protective goggles etc.**

**Avoid contact of skin with oil. Do not allow used oil to spill.**

Worn metal parts remaining after repairs and unsuited for regeneration shall be scrapped. Waste oil and also rubber and plastic elements should be taken to establishments undertaking the utilisation of such materials.



**SECTION**

**2**

---

**SAFETY ADVICE**

## 2.1 BASIC SAFETY RULES

- Before using the machine the user should carefully read this Operator's Manual and the PTO shaft Operator's Manual and adhere to the recommendations contained in these documents.
- The machine may only be used and operated by persons qualified to drive and trained in the use of agricultural tractors.
- If the information stated in the Operator's Manual is difficult to understand, contact a seller who runs an authorised technical service on behalf of the Manufacturer, or contact the Manufacturer directly.
- Be aware of the existence of a minimal risk, and for this reason the fundamental basis for using this machine should be the application of safety rules and sensible behaviour.
- The machine must never be used by persons, who are not authorised to drive agricultural tractors, including children and people under the influence of alcohol or other drugs.
- Non-compliance with the safety rules of this Operator's Manual can be dangerous to the health and life of the operator and others.
- The machine must not be used for purposes other than those for which it is intended. Anyone who uses the machine other than the way intended takes full responsibility for himself for any consequences of this use.
- Any modification to the machine frees the manufacturer from any responsibility for damage or detriment to health which may arise as a result.
- Before using the machine always check its technical condition. In particular check the technical condition of the hitch, PTO drive, cutting system and correct mounting of protective guards.
- Do NOT ride on the machine or transport any materials on it.
- Do NOT hitch mower to tractor, if it does not fulfil the requirements made by the Manufacturer.

- The machine may only be used when all the safety guards and other protective elements are technically sound and correctly positioned. In the event of loss or destruction of the safety guards, they must be replaced with new ones.
- Before hitching the machine to the tractor, check the technical condition of the hitching system of the mower and the tractor.
- Be especially careful when hitching the machine to tractor.
- When hitching the mower, there must be nobody between the mower and the tractor.
- To attach the machine to the tractor only the rear Three Point Linkage may be used. After mounting the machine, check the safeguards.
- To mount machine on tractor use only genuine pins and safeguard cotter pins.
- Before hitching the mower check that both machines are in good technical condition.
- When connecting the hydraulic lines, make sure that the hydraulic system is not under pressure. If necessary, reduce pressure in the system.
- The machine may only be connected to the tractor by appropriately selected PTO shaft recommended by the Manufacturer.
- The PTO shaft has markings on the casing, indicating, which end of the shaft shall be connected to the tractor.
- The chains preventing the shaft cover from turning while the shaft is working, shall be secured to a fixed element of machine structure.
- Do NOT use the securing chains to support the shaft while machine is parked or being transported.
- The drive shaft must be equipped with a cover. Do NOT use the shaft with damaged or missing guards.
- After connecting shaft ensure that it is correctly and safely connected to the tractor and to the machine.
- Before starting PTO shaft make certain that the PTO rotation direction is correct.

- Before using the machine the user should thoroughly acquaint himself with the PTO shaft Operator's Manual and adhere to the recommendations contained in it.
- Disconnect the drive shaft each time when it is not necessary to drive the machine.
- Do NOT go over and under the shaft or stand on it equally during work as also when the machine is parked.
- Do NOT wear loose clothing, straps or whatever that may become wrapped round the rotating drive shaft. Contact with rotating PTO shaft may cause severe injuries.
- The mower may not be used or transported in conditions of limited visibility.
- When transporting the mower mounted on the tractor, close all hydraulic cylinders valves.
- Before lowering or lifting the mower mounted on the three-point linkage, make sure there are no bystanders, especially children, near the machine.
- Before starting the mower make sure that there are no bystanders (especially children) or animals in the danger zone (an area with a radius of up to 50 m from the mower). The machine operator is obliged to ensure proper visibility of the machine and the working area.
- Before starting the mower's PTO shaft, the cutting unit must be in working position.
- Mowing should begin after reaching nominal PTO RPM of 540 rpm. Do NOT overload shaft and mower and also engage the clutch suddenly.
- During cutting do NOT use PTO revolution speed greater than 540 rpm.
- When mowing on the edges of streets, public roads, on stony ground there is a risk that thrown out stones and foreign bodies may pose a risk to bystanders and other vehicle passing by.
- Do NOT leave the tractor cab, when the machine drive is engaged.
- Do NOT stand within the machine's working zone.

- Do NOT approach cutting unit guards until the rotating cutting parts come to a complete standstill.
- Do NOT operate mower while reversing. While reversing lift machine.
- The mower's hydraulic system is under high pressure when operating.
- Before disconnecting the shaft, turn off the tractor engine and remove the key from the ignition.
- Reduce pressure prior to disconnecting the hydraulic system.
- Before disconnecting mower from the tractor's linkage, lock the lifting arm in parking position.
- Mower uncoupled from tractor must be supported on a support leg.
- When operating the machine wear protective gloves and use the appropriate tools.
- Repair, maintenance and cleaning work should be carried out with the tractor's engine turned off and the ignition key removed.
- Regularly check the condition of the bolt and nut connections.
- Regularly check the technical condition of the connections and the hydraulic lines. There must not be any leaks of hydraulic oil.
- During the warranty period, any repairs may only be carried out by authorised Warranty Service.
- In the event of any fault or damage whatsoever, do not use the mower until the fault has been corrected. The machine must not be used when not in working order.
- Repair work should be carried out by persons trained and entitled to do so. This work should be carried out using appropriate tools.
- Should it be necessary to change individual parts, use only those parts indicated by the Manufacturer. Non-adherence to these requirements may put the user and other people's health and life at risk, and also damage the machine.
- In the event of work requiring the mower to be raised, use properly certified hydraulic or mechanical lifts for this purpose. After lifting the machine, stable and

durable supports must also be used. Do NOT carry out work under a machine, which has only been raised with the three point linkage.

- The machine must not be supported using fragile elements (bricks or concrete blocks).
- The paint coating should be cleaned off before beginning welding work. Burning paint fumes are poisonous for people and animals. Welding work should be carried out in a well lit and well ventilated space.
- During welding work pay attention to flammable or fusible elements. If there is a risk that they will catch fire or be damaged, they should be removed or covered with non-flammable material before commencing welding work. The machine must be disconnected from the tractor before commencing electric welding.
- Servicing and repair work should be carried out in line with the general principles of workplace health and safety. In the event of injury, the wound must be immediately cleaned and disinfected. In the event of more serious injuries, seek a doctor's advice.
- After finishing servicing or repair work remove all tools from the machine.
- Damaged, missing or worn cutting blades must be replaced in pairs in order to maintain the balance of the cutting disc.
- After completing work associated with lubrication, remove excess oil or grease. The mower should be kept clean and tidy.
- Do NOT install additional fittings not according to the specifications defined by the Manufacturer.
- In order to reduce the danger of fire the machine must be kept in a clean condition.
- In order to limit occupational risks associated with exposure to noise during mower operation use individual protection (ear protectors).

## 2.2 DRIVING ON PUBLIC ROADS

- When driving on public roads, comply with the road traffic regulations.

- Do not exceed the maximum speed when travelling. Adjust driving speed to the road conditions.
- Before beginning travel, the mower must be placed in transport position and raised using the rear three-point linkage system. When parked, the machine should be lowered.
- When preparing the mower for the transport check if the tipping cylinder mechanical interlocks are in the appropriate position and if hydraulic cylinder valves are in CLOSED position.
- During transport disconnect PTO shaft from tractor.
- Do NOT leave tractor driver's seat when the tractor is moving.

## 2.3 DESCRIPTION OF MINIMAL RISK

Pronar Sp. z o. o. in Narew has made every effort to eliminate the risk of accidents. There is, however, a certain minimal risk, which could lead to an accident, and this is connected mainly with the actions described below:

- using the machine for purposes other than those for which it is intended,
- operation of the machine by persons under the influence of alcohol,
- being between the tractor and the machine while the engine is running and when the machine is being hitched,
- operating the machine with removed or faulty safety guards;
- not maintaining safe distance from the danger zone or being within the zones while the machine is operating,
- being on the machine while the engine is running,
- cleaning, maintenance and technical checks when tractor's engine is running;
- presence of persons or animals in areas invisible from the driver's position;
- making modifications to the machine without the consent of the Manufacturer,
- oil leaks and sudden movement of elements resulting from line cracking,
- using unreliable PTO shaft,

The minimal risk may be kept to a minimum by following the recommendations below:



- prudent and unhurried operation of the machine,
- application of the remarks and recommendations stated in the *OPERATOR'S MANUAL*;
- maintaining safe distance from the danger zone
- a ban on being on the machine and in the vicinity when it is operating,
- carrying out repair and maintenance work in line with operating safety rules,
- using suitable protective clothing
- ensuring unauthorised persons have no access to the machine, especially children.



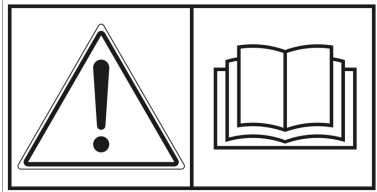

## 2.4 INFORMATION AND WARNING DECALS

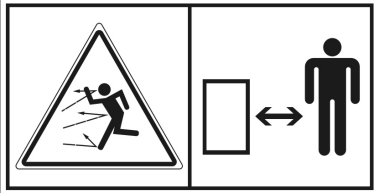
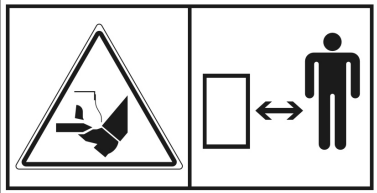
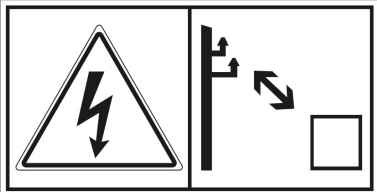

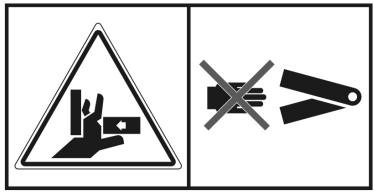

The mower is labelled with the information decals mentioned in table (2.1). The symbols are positioned as presented in figure (2.1). Throughout the time it is in use, the user of the machine is obliged to take care that notices and warning and information symbols located on the mower are clear and legible. In the event of their destruction, they must be replaced with new ones. Safety decals are available from your PRONAR dealer or directly from PRONAR customer service. During cleaning do not use solvents, which may damage label covering and do not direct strong water jet at machine.

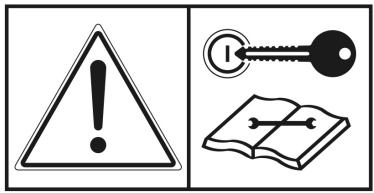
**TABELA 2.1 Information and warning decals**

ITEM	DECAL	MEANING
1		<p>Before starting work, carefully read the Operator's Manual.</p>

ITEM	DECAL	MEANING
2		<p>Risk of injury when machine is being arranged in transport or working position.</p>
3		<p>Thrown out objects, endanger the whole body. Keep a safe distance from the operating machine.</p>
4		<p>Risk of injury to foot or leg. Keep a safe distance.</p>
5		<p>Keep a safe distance from electric power lines.</p>
6		<p>Danger - cutting elements! Do NOT approach an operating machine.</p>
7		<p>Do not touch any rotating elements until they come to a complete standstill.</p>

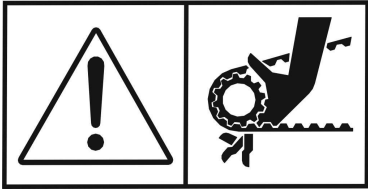
ITEM	DECAL	MEANING
8		<p>Danger associated with the rotating PTO shaft.</p>
9		<p>Do not reach into crushing space because elements may move. Danger of crushing hands or fingers.</p>
10		<p>Maximum allowable PTO shaft rotation speed is 540 rpm.</p>
11		<p>Maximum allowable PTO shaft rotation speed is 1 000 rpm.</p>
12		<p>Before beginning servicing or repairs, switch off engine and remove key from ignition</p>
13		<p>Do not stand behind the tractor while lifting arm is operated.</p>

ITEM	DECAL	MEANING
14		Transport lug points marking.
15		Lubrication points
16	<div style="border: 1px solid black; padding: 5px; display: inline-block;"><b>PDT260 PRONAR</b></div>	Machine type PDT260.
17	<div style="border: 1px solid black; padding: 5px; display: inline-block;"><b>PDT300 PRONAR</b></div>	Machine type PDT300.
18	<div style="border: 1px solid black; padding: 5px; display: inline-block;"><b>PDT340 PRONAR</b></div>	Machine type PDT340.
19	<div style="border: 1px solid black; padding: 5px; display: inline-block;"><b>PDT260C PRONAR</b></div>	Machine type PDT260C.
20	<div style="border: 1px solid black; padding: 5px; display: inline-block;"><b>PDT300C PRONAR</b></div>	Machine type PDT300C.
21		Note — The drive chain or toothed belt drive. Exercise particular caution
22		Caution! Rotor Exercise particular caution

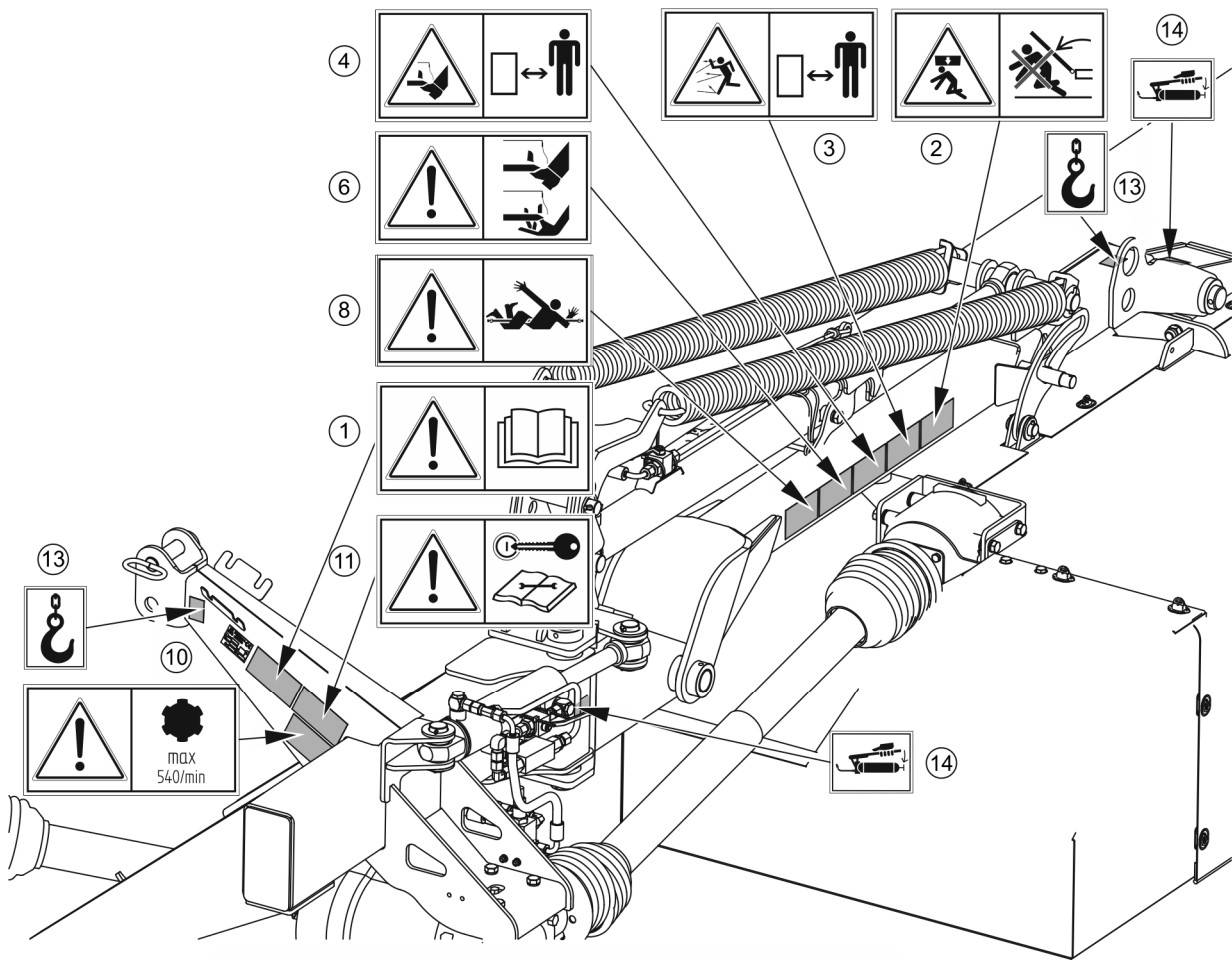

**PDT260 PRONAR**  
**PDT300 PRONAR**  
**PDT340 PRONAR**

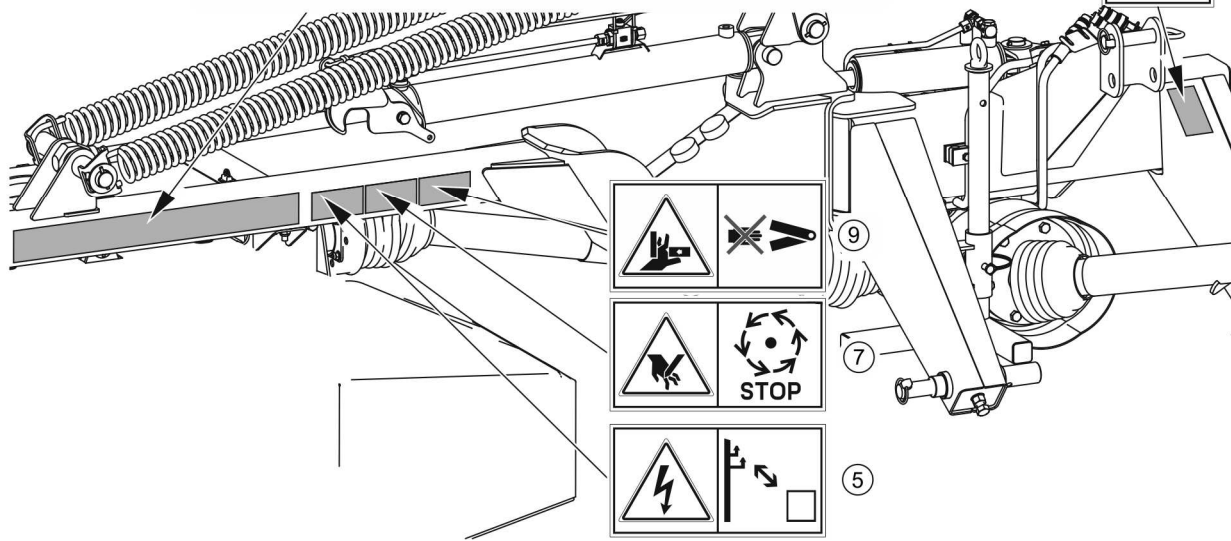
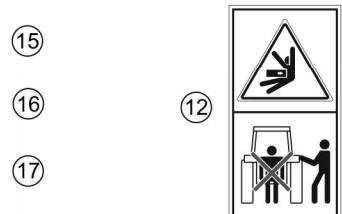

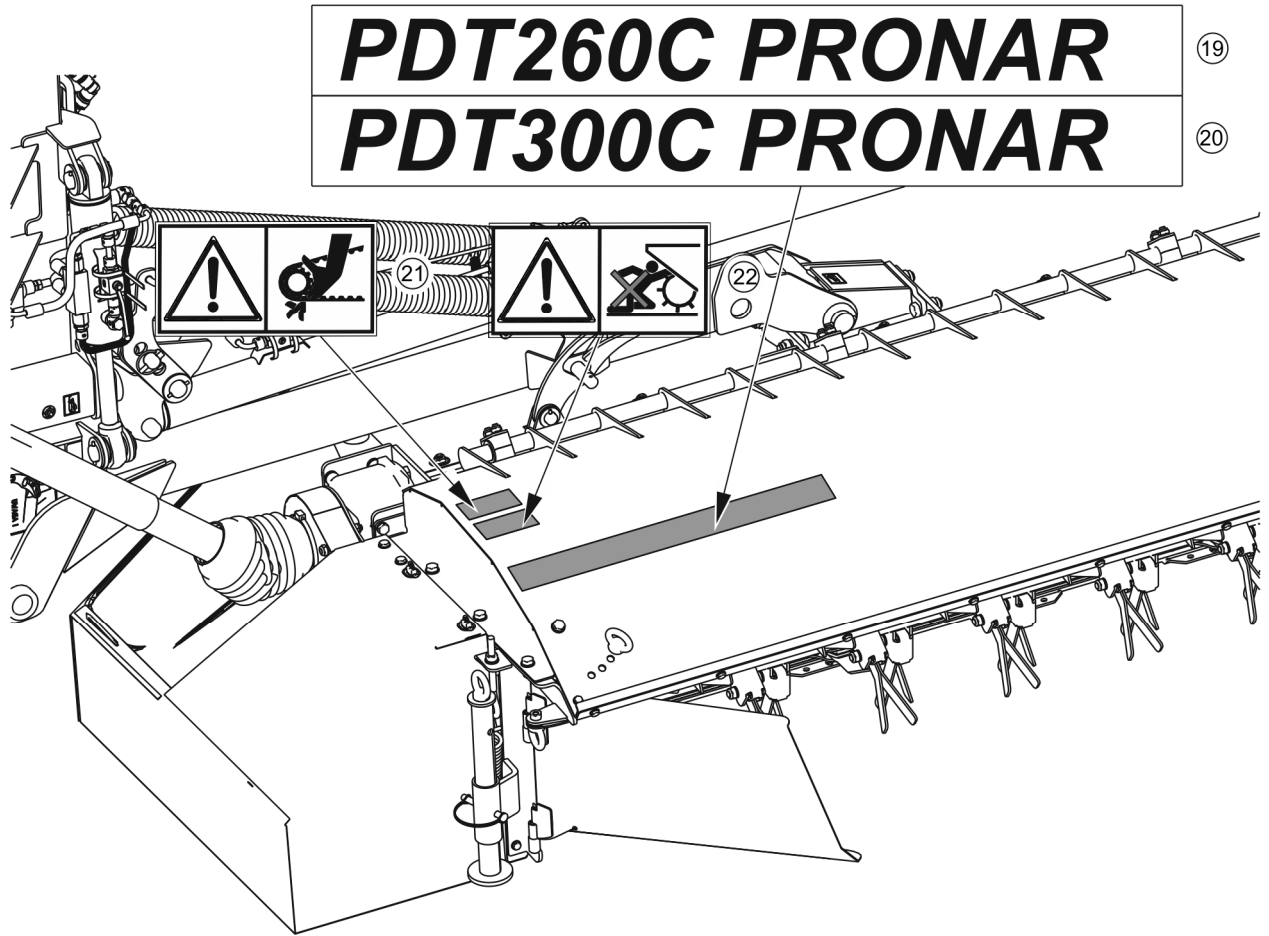



*SECTION*

**3**

---

**DESIGN AND  
OPERATION**

### 3.1 TECHNICAL SPECIFICATION

**TABLE 3.1 Basic technical specification**

CONTENTS	UNIT	PDT260	PDT300	PDT340
<b>Dimensions</b>				
Total width in working setting	mm	4 500	4 920	5 340
Total height in working setting	mm	1 300		
Total length in working setting	mm	1 290		
Length in working setting with swath conditioner (PDT260C PDT300C)	mm	1 765		-
Length in transport setting min / max	mm	1 290/3990	1 290/4410	1 290/4830
Length in transport setting min / max with swath conditioner (PDT260C PDT300C)	mm	1 765/3990	1 765/4410	-
Width in transport setting min / max	mm	1 430 / 1 760		
Width in transport setting min / max with swath conditioner (PDT260C PDT300C)	mm	1 735 / 1 760		-
Height in transport setting min / max	mm	1 480/3320	1 480/3740	1 480/4160
<b>Technical specification</b>				
Cutting width	mm	2 600	3 000	3 400
Swath width min / max	mm	1 200/1600	1 200/2000	1 500/2400
Swath width min / max with swath conditioner (PDT260C PDT300C)	mm	1300/1 900	1700/2 350	-
Performance (at recommended cutting speed)	ha/h	2.6	3.0	3.4
Tare weight	kg	640	740	800
Tare weight with a conditioner (PDT260C PDT300C)	kg	860	1 000	-

CONTENTS	UNIT	PDT260	PDT300	PDT340
Minimum power demand	kW / Horsepower	33 / 45	44 / 60	59 / 80
Minimum power requirement with swath conditioner (PDT260C PDT300C)	kW / Horsepower	44 / 60	55 / 75	-
Maximum PTO speed	RPM	540	1 000	
Driveshaft torque	Nm	900		
Linkage	-	II and III according to ISO 730		
Number of discs	item	6	7	8
Number of cutting blades	item	12	14	16
Type of cutting blades	-	twisted		
Dimensions of cutting blades	mm	120x49x4 Ø21		
Rotation speed of discs	RPM	3 130	3 000	
Recommended mowing speed	km/h	10		
<b>Noise emission level</b>				
$L_{WA}$	dB	94.2	96.1	92.9

$L_{WA}$  – acoustic power level,

### 3.2 GENERAL DESIGN

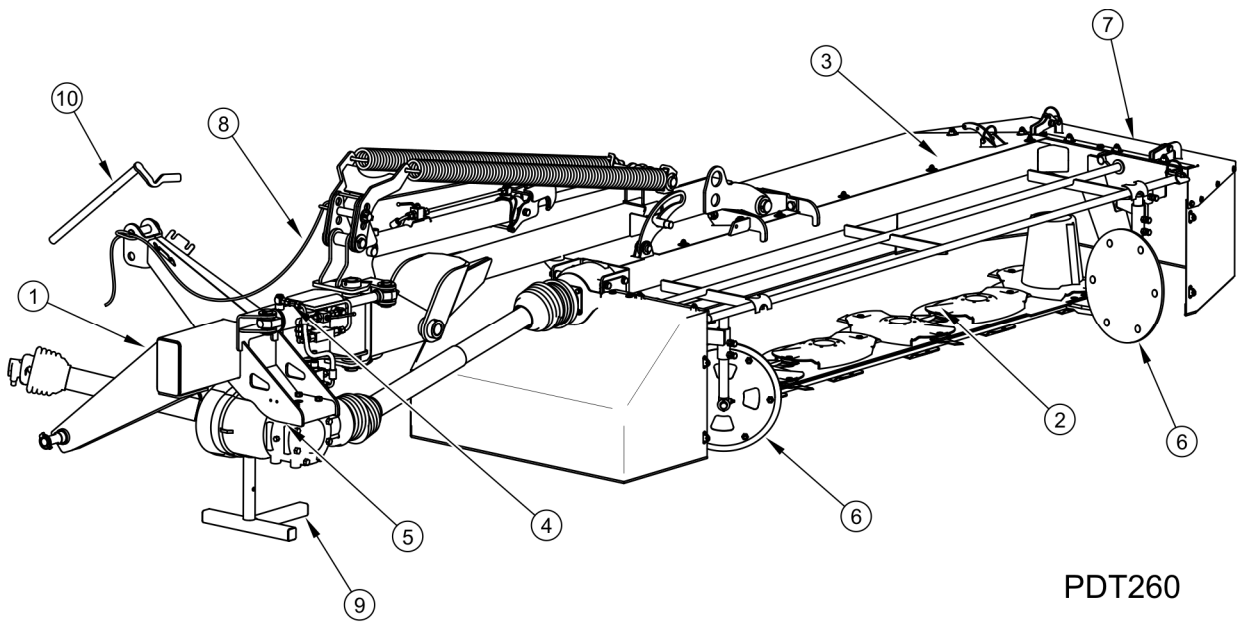

PDT260

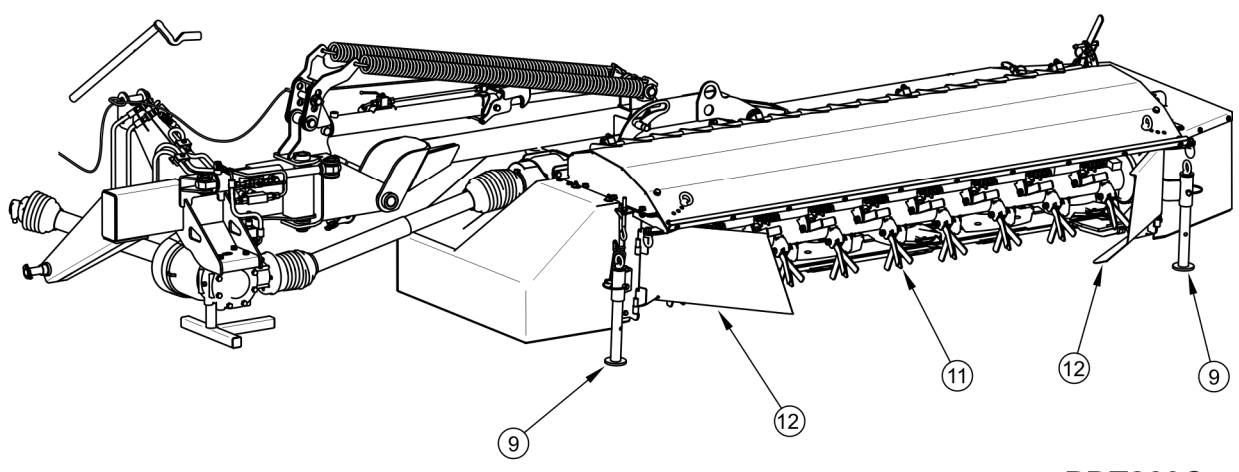

PDT260C

**FIG. 3.1 Design of the mower**

(1) linkage; (2) cutting unit; (3) main frame; (4) hydraulic system; (5) drive transmission; (6) swath guide; (7) guards; (8) interlock cable; (9) support, (10) key for changing cutting blades (11) swath conditioner shaft (12) swath guide

### 3.3 LINKAGE

The main element of the mower linkage (figure 3.2) is the three-point linkage frame (1), equipped with two lower pins (4) and upper pin (5) for connection to the tractor's rear three point linkage. Moving arm (3) allows the cutting unit to swing backwards. Lifting arm (2) raises the cutting unit. To relieve the cutting unit, springs (6) are used, whose tension can be adjusted by changing the positioning of the pin (8). Using the pin (9) lifting arm can be interlocked (2) when mower is disconnected from the tractor.

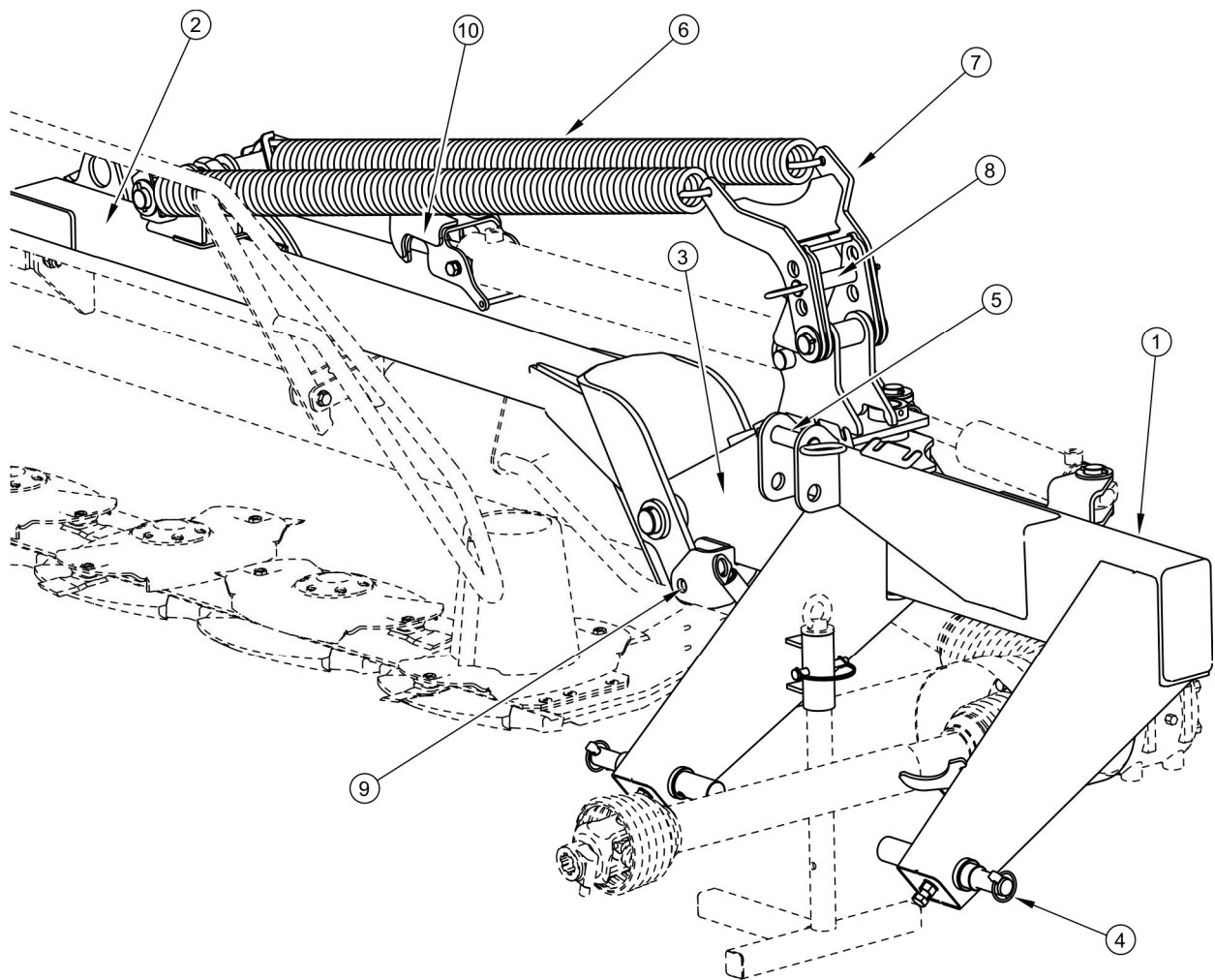

**FIG. 3.2** Mower linkage

(1) three-point linkage frame; (2) lifting arm; (3) moving arm; (4) three-point linkage lower hitching eye pin; (5) central connection pin; (6) stay springs; (7) spring catch; (8) spring tensioning pin; (9) lifting arm interlock pin; (10) cylinder lock

### 3.4 HYDRAULIC SYSTEM

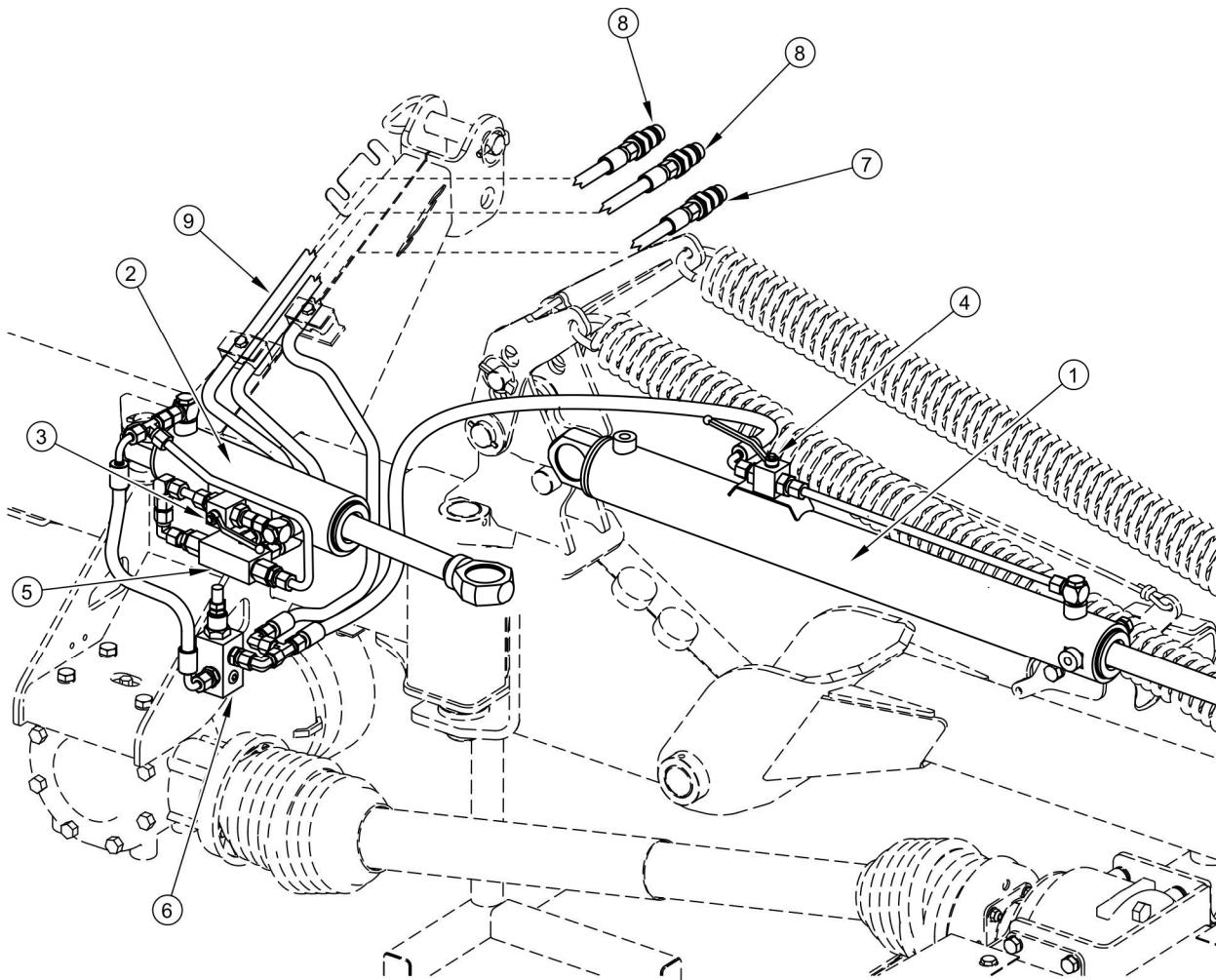

**FIG. 3.3** Hydraulic system design

(1) hydraulic lifting cylinder; (2) hydraulic tipping cylinder - hydraulic safety device; (3) tipping cylinder interlocking valve; (4) lowering cylinder interlocking valve; (5) hydraulic lock; (6) overflow valve; (7) hydraulic quick coupling for lifting control; (8) hydraulic quick coupling for tipping control; (9) hydraulic lines

## 3.5 DRIVE TRANSMISSION

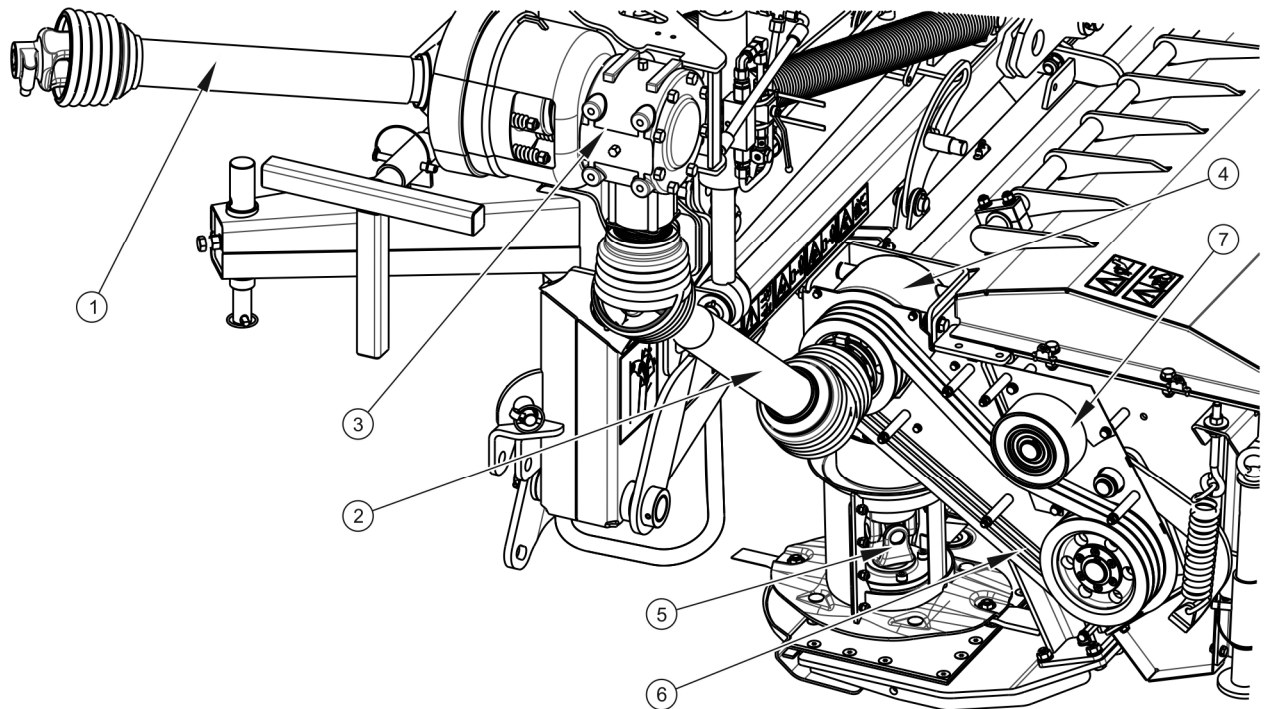
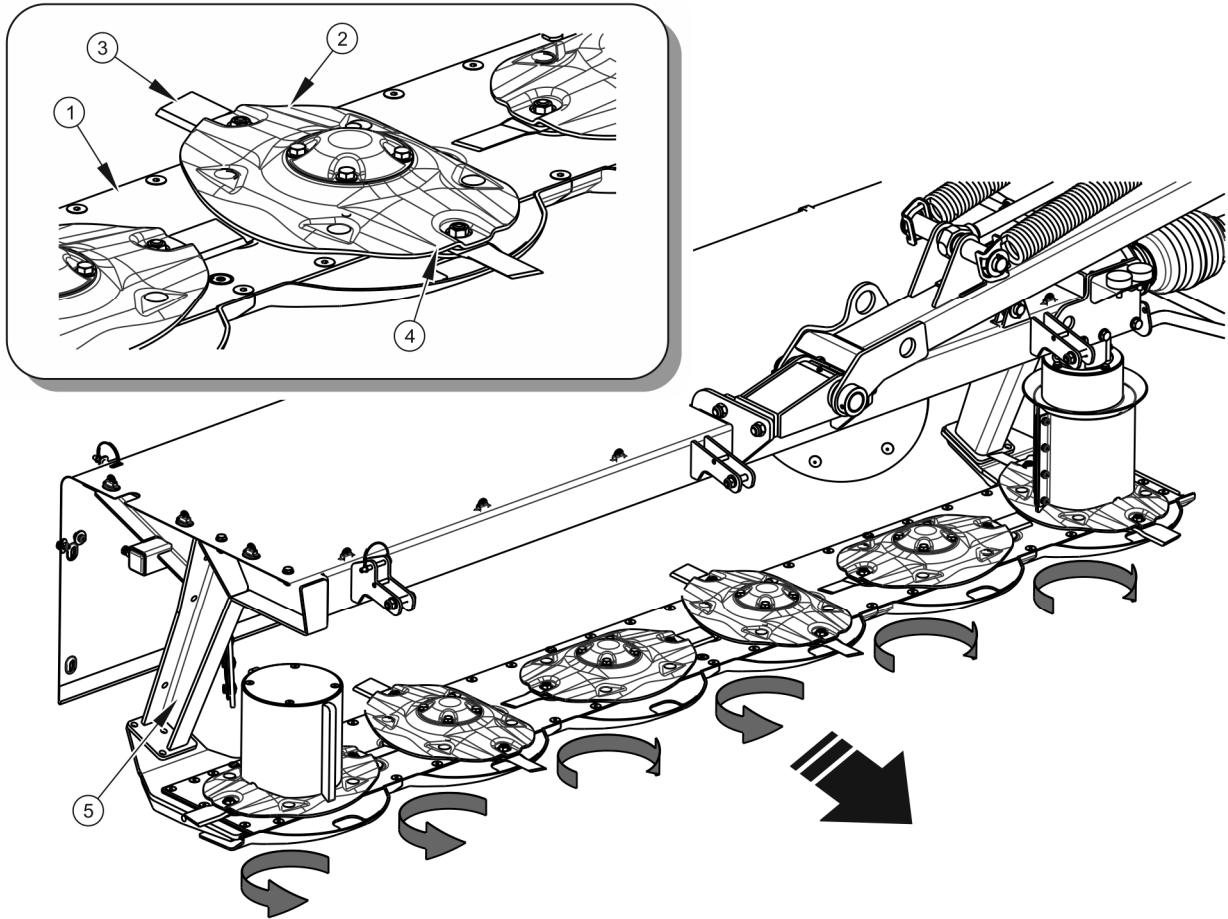

**FIG. 3.4** Drive transmission

(1) PTO shaft with backstop overload release clutch; (2) PTO shaft; (3) intersecting axis gear I; (4) intersecting axis gear II; (5) connector, (6) belt transmission (PDT260C, PDT300C), (7) tensioner (PDT260C, PDT300C)

Torque is transmitted from PTO through a PTO shaft (1) equipped with a friction backstop overload release clutch. Next torque from intersecting axis gear (3) using the shaft (2) is transmitted to the intersecting axis gear II and then through the connector (5) to the cutter bar. In the version of the mower with swath conditioner, the conditioner is driven by intersecting axis gear (4) through belt transmission (6) with tensioner (7). Belt transmission transmits torque to the conditioner shaft with three belts SPB 1 525.

### 3.6 CUTTING UNIT

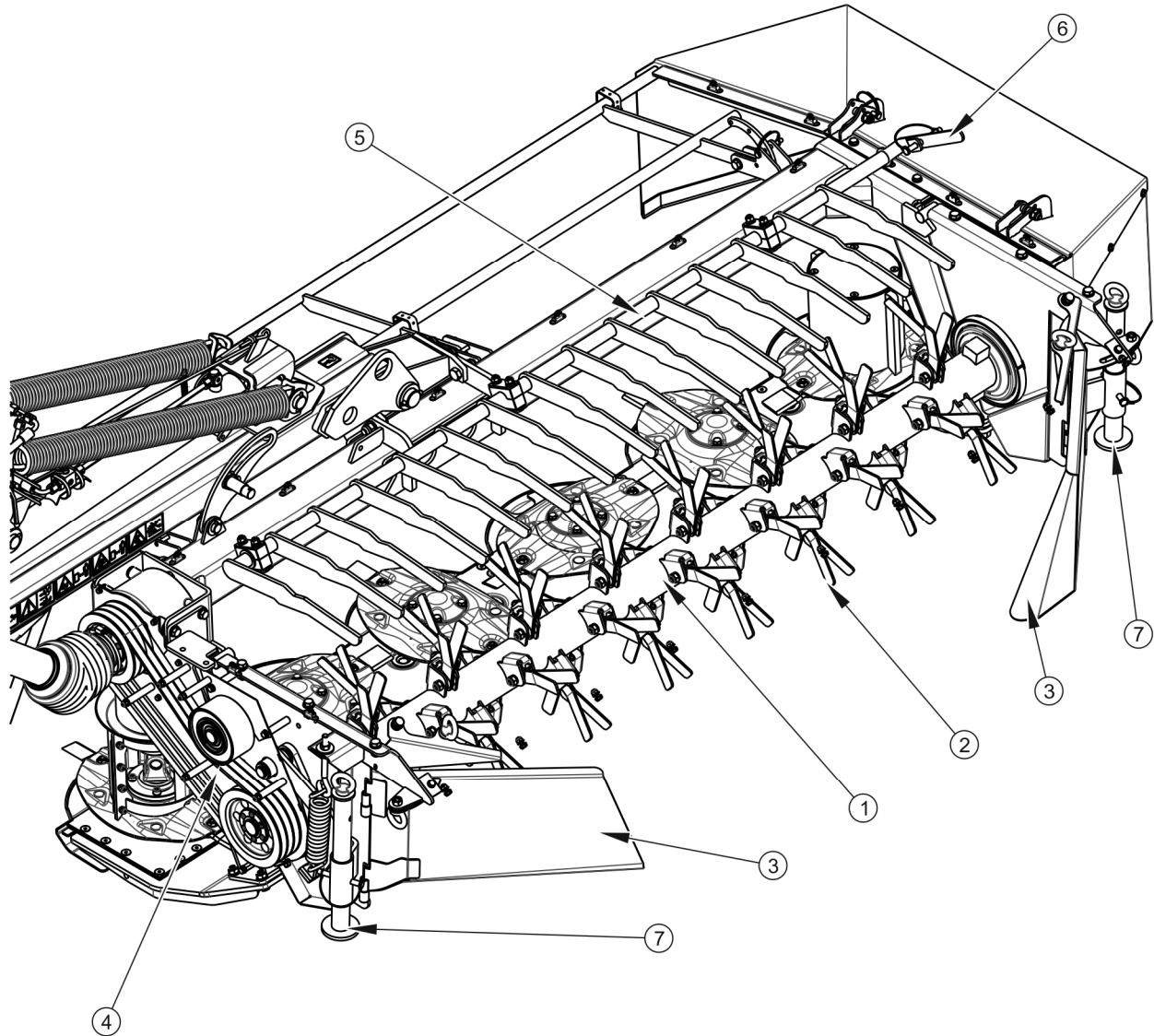

**FIG. 3.5 Drive transmission**

*(1) cutterbar, (2) cutting disc, (3) knife, (4) knife holder, (5) foot*

Cutting unit of the mower comprises the cutter bar (1) on which cutting discs (2) are mounted. The cutter bar is mounted to the frame with the aid of a foot (5). Two cutting blades are mounted on each of the cutting discs, right or left depending on disc rotation direction. Disks are equipped with knife holders (4). Rotation direction of individual discs is shown on figure (3.5).

### 3.7 SWATH CONDITIONER UNIT (PDT260, PDT300)



**FIG. 3.6 Drive transmission**

(1) swath conditioner shaft, (2) flail blades, (3) swath guides, (4) belt transmission; (5) damping fingers; (6) damping finger adjusting lever, (7) conditioning assembly supports

PRONAR PDT260C and PRONAR PDT300C mower conditioning assembly consists of a shaft (1) on which flail blades (2) are fitted. Swath conditioner flail blades intercept material from the cutter bar and toss it over the conditioner shaft (2) to swath guides (3), which form a swath of a specific width depending on the setting. The conditioning intensity can be adjusted using the lever (6), which sets the damping fingers (5) relative to the conditioner shaft so that

the material is properly formed and conditioned. The entire conditioning assembly is driven by the intersecting axis gear through belt transmission (4), which in turn is driven by the cutterbar.

*SECTION*

**4**

---

**CORRECT USE**

## 4.1 PREPARING FOR WORK

The manufacturer guarantees that the machine is fully operational and has been checked according to quality control procedures and is ready for use. This does not release the user from an obligation to check the machine's condition after delivery and before first use. The machine is delivered to the user completely assembled.

Before connecting to tractor, machine operator must check the technical condition of the mower and prepare it for test start-up. In order to do this:

- the user must carefully read this Operator's Manual and observe all recommendations, understand the design and the principle of machine operation
- check the condition of protective paint coat,
- Inspect machine's individual components for mechanical damage resulting from incorrect transport (dents, piercing, bent or broken components),
- check all the lubrication points, lubricate the machine as needed according to recommendations provided in section 5 "*MAINTENANCE*",
- check technical condition of the hydraulic system;
- check if cutting blades, cutter bar, lifting arms and safety guards are correctly installed,
- check technical condition of hitching system pins and locking cotter pins,
- check lubricating oil level in intersecting axis gears.

If all the above checks have been performed and there is no doubt as to the machine's good technical condition, it can be connected to tractor. Start the tractor's engine, check all systems and perform a test run before beginning work. In order to inspect:

- connect the mower to tractor,
- set in working position,
- adjust the length of PTO shaft according to Operator's Manual of PTO shaft recommendations,
- connect PTO shaft to tractor and mower,
- start PTO drive.

Engage mower's drive for 3 minutes and check the following:

- that there is no knocking or noise in the drive system arising from scraping or grinding of metal elements,
- whether there is excessive vibration in the cutting unit,
- synchronised rotation of cutting unit,



### **IMPORTANT!**

**Before using the mower always check its technical condition. In particular check the technical condition of the cutting unit, linkage, drive system, and integrity of protective guards.**

The mower's operation at no load should be smooth. Shaking of drive transmission, cutting unit and whole machine is not acceptable, nor is changed noise and vibrations coming from loose nut and bolt connections. After stopping mower, check fastening of cutting blades. Check that gear oil does not leak from reduction gear and cutter bar.



### **DANGER**

**Before using the mower, the user must carefully read this operator's manual.**

**Careless and improper use and operation of the mower, and non-compliance with the recommendations given in this operator's manual is dangerous to your health.**

**The mower must never be used by persons, who are not authorised to drive agricultural tractors, including children and people under the influence of alcohol or other drugs.**

**Non-compliance with the safety rules of this Operator's Manual can be dangerous to the health and life of the operator and others.**

**Before starting the mower make sure that there are no bystanders (especially children) or animals in the danger zone (an area with a radius of up to 50 m from the mower).**

The trailer may be hitched only when all preparatory activities including inspection of technical condition have been completed satisfactorily. If during test run worrying symptoms or other faults occur, find the cause of the problem. If a fault cannot be rectified or the repair could void the warranty, please contact retailer for additional clarifications or to perform repair.



**IMPORTANT!**

Before connecting the PTO shaft adjust the length of PTO shaft according to the PTO shaft Operator's Manual.

## 4.2 CHECKING TECHNICAL CONDITION

When preparing the mower for normal use, check individual elements according to guidelines presented in table (4.1).

**TABLE 4.1 TECHNICAL INSPECTION SCHEDULE**

DESCRIPTION	SERVICE OPERATION	FREQUENCY
Condition of safety guards	Check technical condition of safety guards, if complete and correctly mounted.	Daily
check if cutter bar and lifting arm are correctly installed,	check if correctly installed	
Technical condition of cutting blades	Visually inspect and if necessary replace according to section „CHECKING AND REPLACING CUTTING KNIVES”	
Check lubricating oil level in intersecting axis gears	For details please refer to section "DRIVE SYSTEM OPERATION"	
Check oil level in cutter bar	For details please refer to section "CUTTER BAR OPERATION"	
Technical condition of the conditioner blades and fingers (PDT260C, PDT300C)	Visually inspect and if necessary replace according to section „CHECKING AND REPLACING CUTTING KNIVES”	
Tightening of all main nut and bolt connections	Torque values should be according to table (5.4)	Every six months
Lubrication	Lubricate elements according to table LUBRICATION.	According to table (5.3)

**IMPORTANT!**

Do NOT use unreliable mower.

## 4.3 HITCHING TO TRACTOR

Mower can be attached to a tractor that meets the requirements contained in Table (1.1) REQUIREMENTS FOR A TRACTOR.

**IMPORTANT!**

Before using the mower, the user must carefully read the tractor operator's manual.

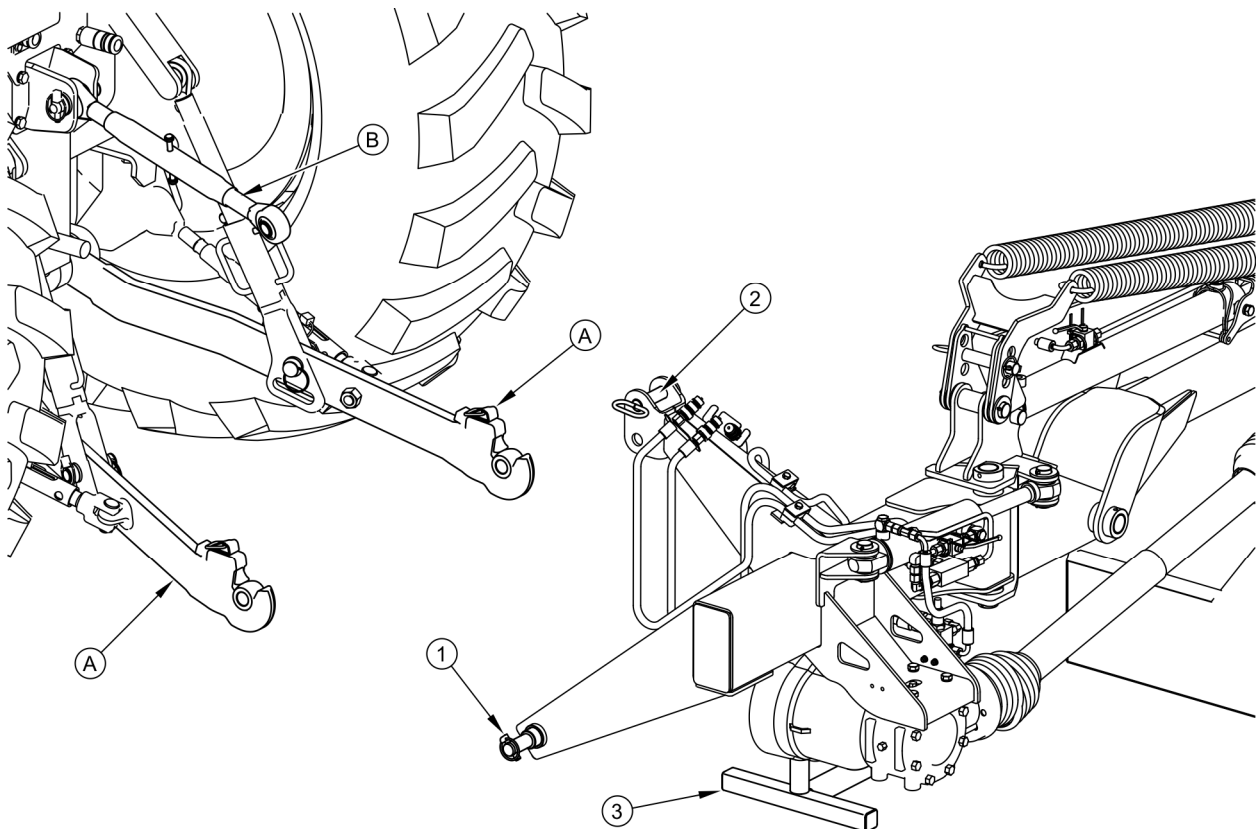

**FIG. 4.1** Hitching to tractor

(A) three point linkage arms, (B) top link, (1) lower pin, (2) upper tension rod mounting pin, (3) support

**DANGER**

Exercise caution when hitching the machine.

When hitching, there must be nobody between the machine and the tractor.

In order to attach the mower to tractor, proceed as follows:

- Reversing the tractor bring the lower three point linkage connection points (A) of the tractor close to pins (1) of the mower.
- Set links (A) of tractor at appropriate height.
- Switch off tractor's engine and prevent it from moving.
- Connect lower pins (1) with linkage arms (A) and lock with the aid of cotter pins.
- Connect top link (B) of tractor with pin (2) mower and lock with cotter pin.
- Lift mower using tractor's three point linkage.
- Raise support (3) (figure (4.12)) and secure with cotter pin.
- Raise the support (2) - Fig. (4.15) and the supports (7) – Fig. (3.6) of the swath conditioner unit (PDT260C and PDT300C) and secure with a cotter pin.
- Unblock bearing arm removing pin (1) from block (figure 4.4).

**TIP**

Set both tractor lower linkage arms at the same height.

**IMPORTANT!**

After hitching mower to tractor remove bearing arm pin (1) from block (figure 4.4).

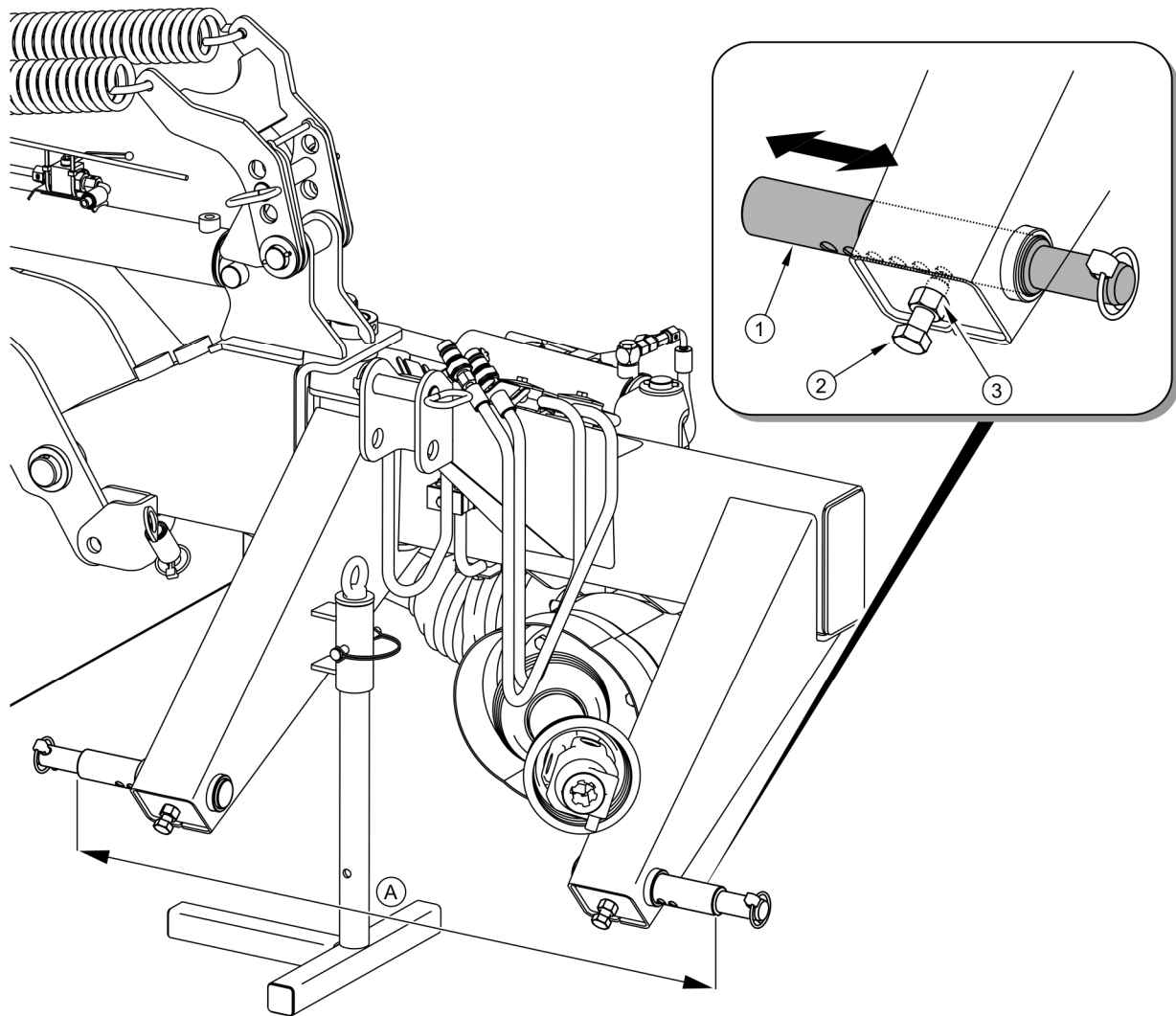

**FIG. 4.2 Hitching to tractor**

(A) adjusted pin spacing in range 795 ÷ 970mm, (1) mower linkage lower pins, (2) retaining bolt, (3) counter nut

Lower pins (1) of the mower linkage enable spacing adjustment (figure 4.2) in range 795 - 970 mm. To change spacing of linkage pin spacing:

- loosen counter nut (1),
- unscrew setting bolt (2),
- move pin (1) to the right or the left to obtain the required spacing,
- block pin position with setting bolt (2) and counter nut (3).

The method of adjustment of right and left pins is identical.

As standard mower is equipped with pins for linking with category II linkage according to ISO 730. To adapt the mower for category III linkage, the optional pins should be used.



**ATTENTION!**

Comply with the recommendations relating to linkage and mounting points.

Line connections of the raising cylinder of the cutting unit lifting frame should be connected to the hydraulic circuit in so-called "floating section". Line connections of tipping cylinder of the lifting frame should be connected to double acting hydraulic circuit.



**DANGER**

Prior to connecting hydraulic system lines the user must carefully read the tractor operator's manual and observe all recommendations of the Manufacturer.

When connecting the hydraulic lines to the tractor, make sure that the tractor hydraulic system is not under pressure.

## 4.4 TRANSPORTING THE MACHINE

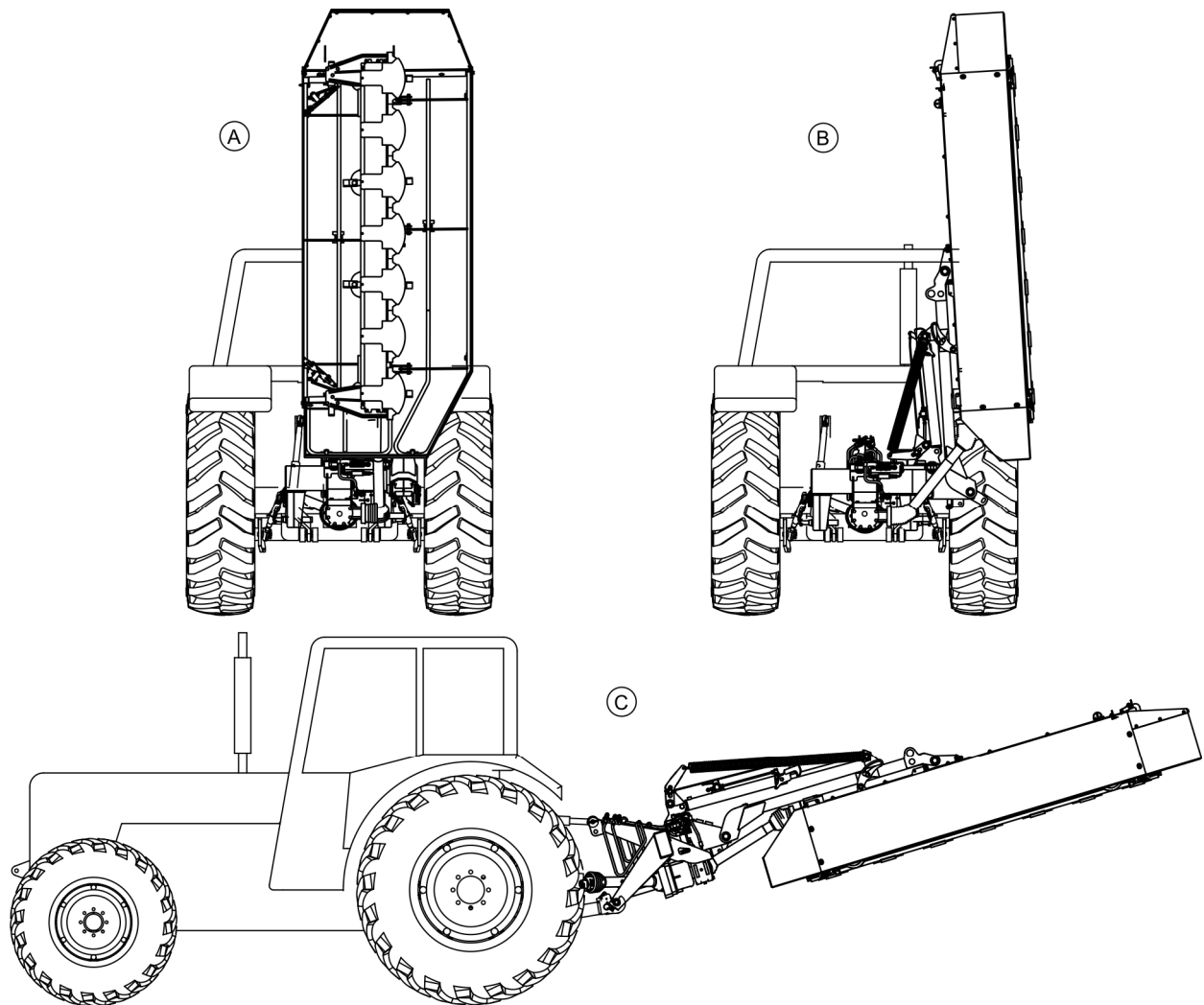

**FIG. 4.3**      **Hitching to tractor**

*(A), (B), (C)- transport positions*

For transport to place of work and back, raise mower on tractor three point linkage so that the lower pins are at height of not less than 500 mm above the ground. Disconnect PTO shaft from tractor's PTO and place on support.

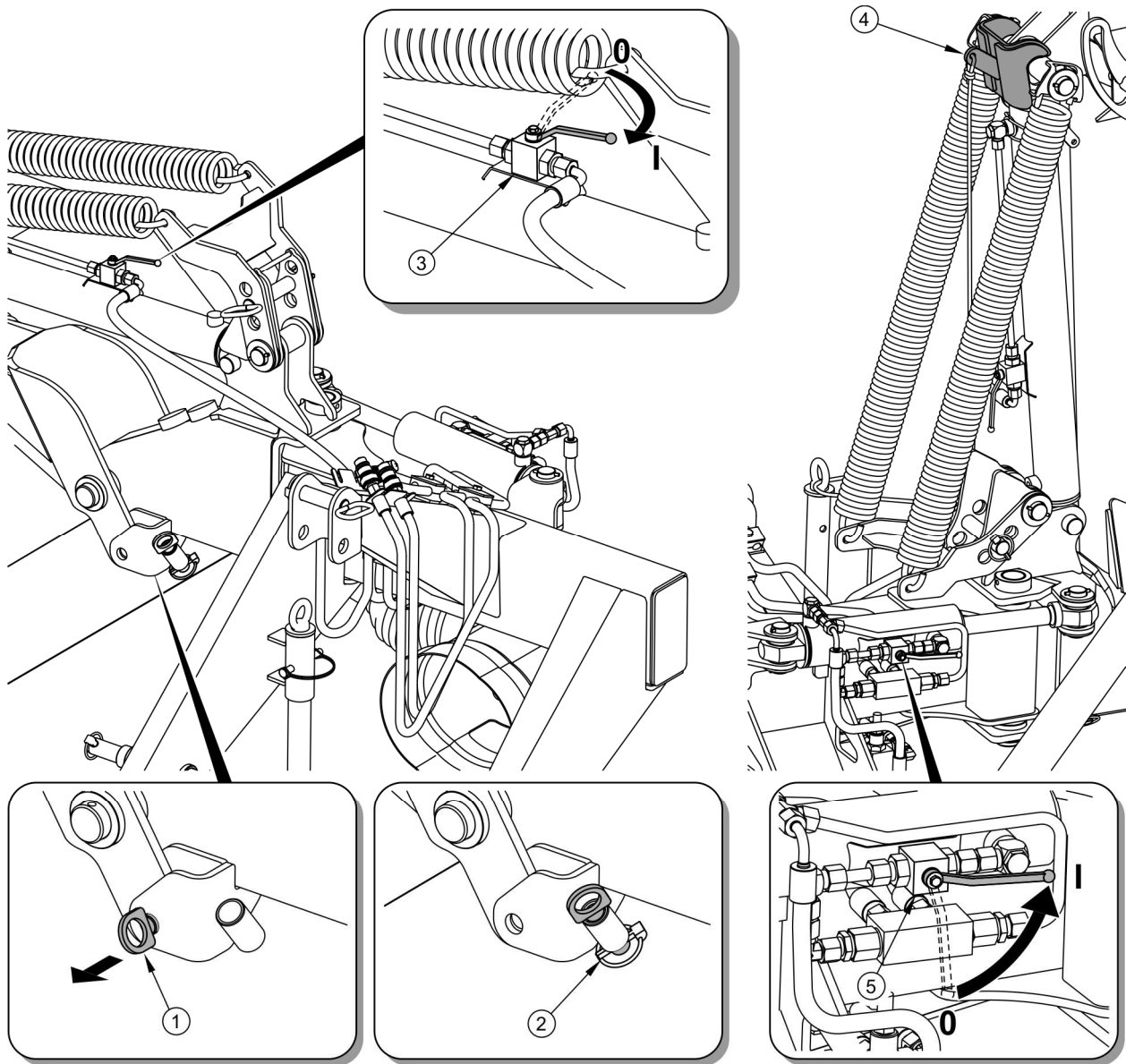

**FIG. 4.4**      **Setting transport position**

(1) lifting arm interlock pin; (2) cotter pin; (3) lifting arm cylinder interlock valve; (4) cylinder lock; (5) tipping cylinder interlock valve; (I) valve open; (0) valve closed

The mower can be set in one of three transport positions. (figure (4.3)).

To set the mower in (A) position:

- Release and remove arm interlocked pin (1) (figure (4.4)), place it in the sleeve and secure with a cotter pin (2),
- Set cylinder intelock valve (3) in open position „I”

- operating the hydraulic cylinder, lift the lifting arm together with cutting unit until cylinder lock (4) is engaged.
- close lifting cylinder valve (3).

To set the mower in (B) position:

- Perform the procedure listed for (A) position
- set valve (5) in open position „I”
- operating the cylinder, swing the cutting unit sideways,
- close tipping cylinder valve (5).

To set the mower in (C) position:

- Lift the mower on three-point linkage
- set valve (5) in open position „I”
- operating the cylinder, swing the cutting unit backwards,
- close tipping cylinder valve (5).

In (C) transport position the mower can be transported only short distances at an appropriately reduced travel speed.

Three point linkage lower arms must be secured so that mower does not swing sideways.



## **DANGER**

**When transporting mower mounted on the tractor, check if tipping cylinder locks are properly secured and if cylinder valves are set in 0 position– closed (A) — figure (4.4)**

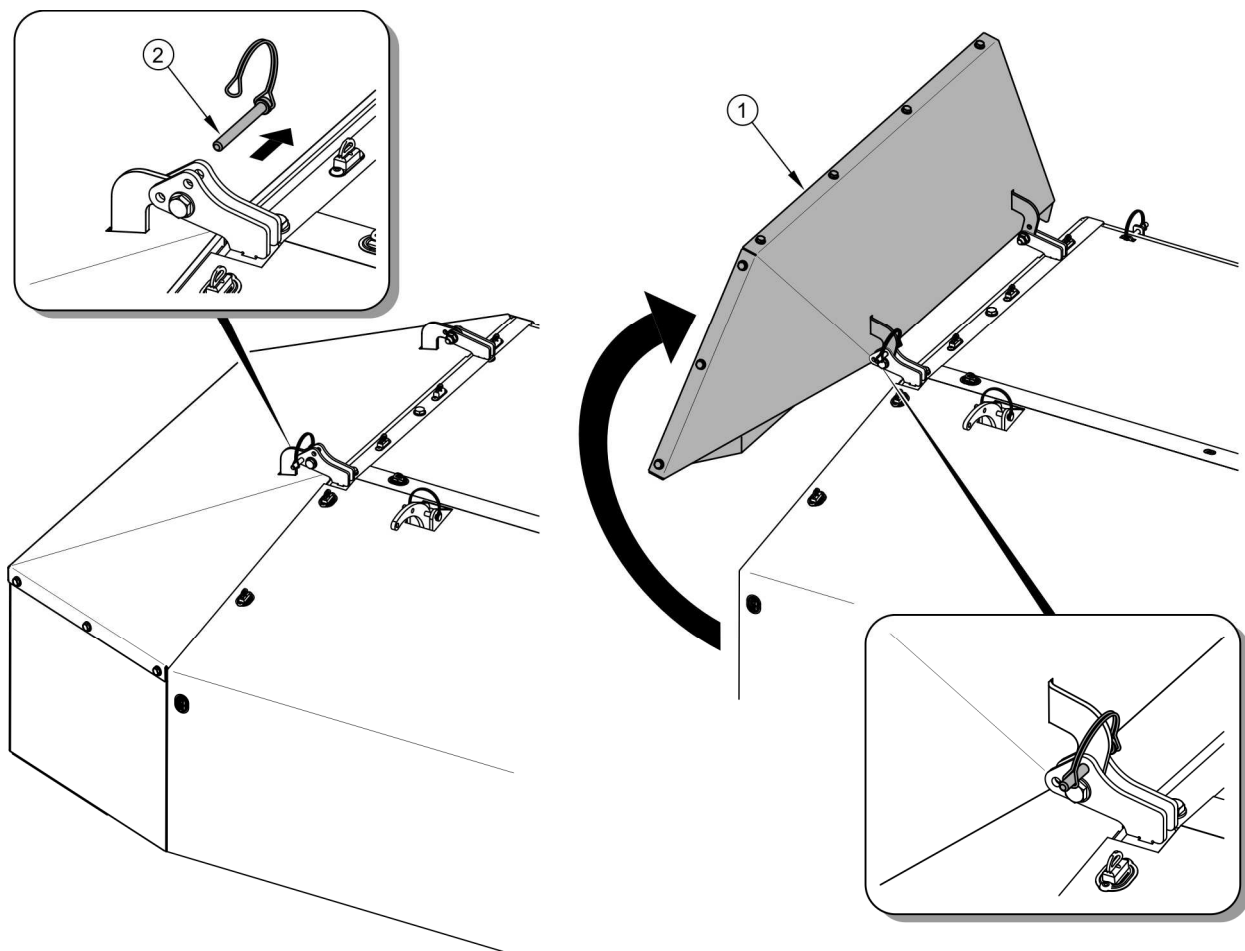

**FIG. 4.5**      **Cutting unit lateral shield**

(1) cutting unit lateral shield; (2) securing pin

In order to reduce the height of mower set in A and B transport positions, open lateral guard (1) before raising the cutting units and lock it in this position. To open the guard:

- release and take out securing pin (2),
- raise lateral guards (1),
- secure guards open position (2) placing pin in appropriate bracket opening.

## 4.5 SETTING AND MOWING

### 4.5.1 SETTING MOWER IN WORKING POSITION

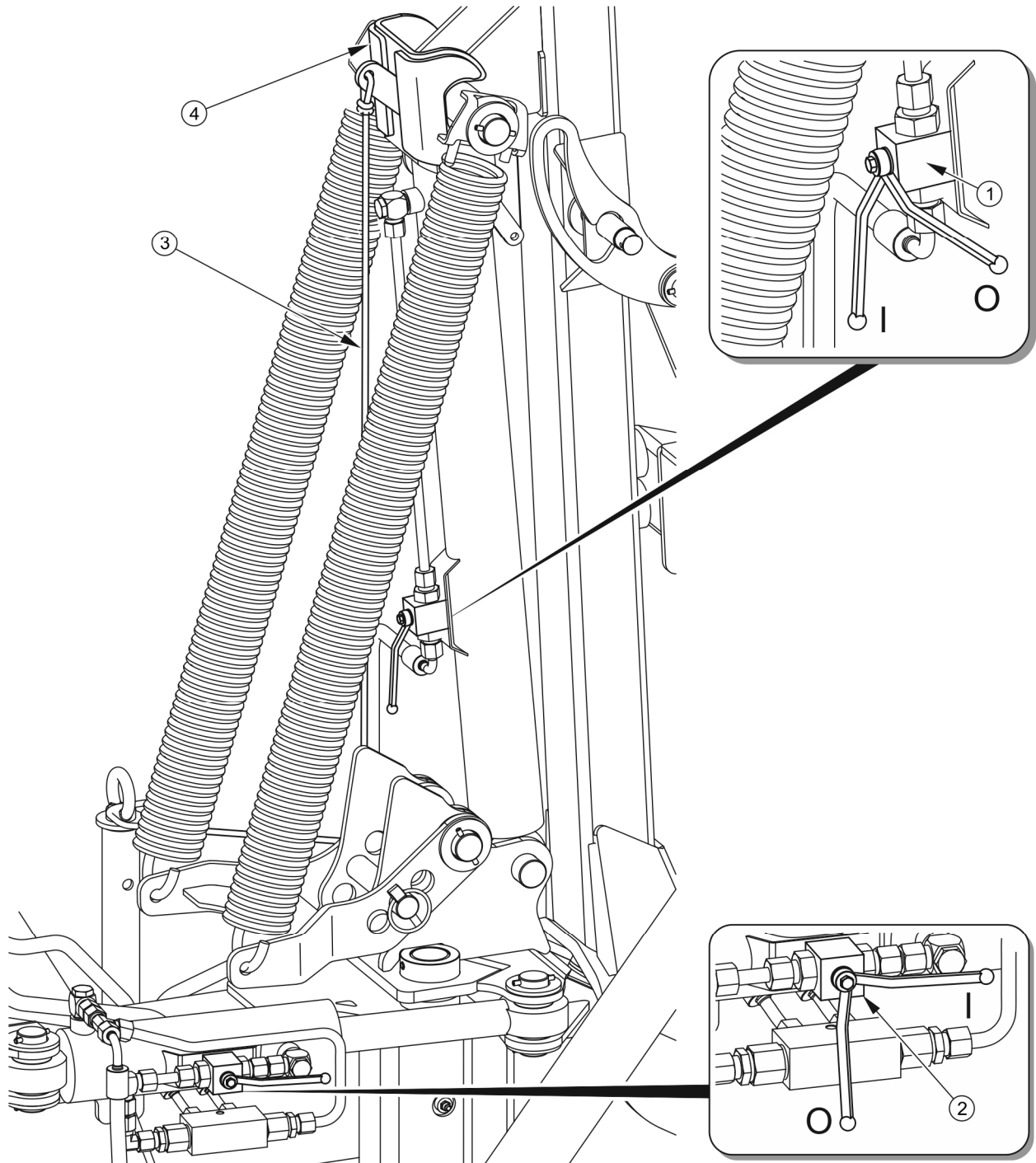

**FIG. 4.6** setting mower in working position

(1) lifting arm hydraulic cylinder interlock valve, (2) tipping cylinder interlock valve,  
(3) cylinder lock cable; (4) cylinder lock

To set the mower in working position:

- set valves (1) and (2) of the tipping and lifting cylinders in open position „I” – figure (4.6),
- Controlling appropriate hydraulic circuits in the tractor, maximally extend the tipping cylinder and withdraw the cylinder of the lifting arm.
- Release lock (4) by pulling cable (3) and by operating the tractor's hydraulic circuit, lower lifting arm with cutting unit so that the cutter bar is supported freely on the ground Set tractor's hydraulic circuit in float position,
- set tractor three point linkage at a height of approx. A= 400 mm - figure (4.7) so that the pin is more or less in mid lock range (3).

#### 4.5.2 SETTING CUTTING HEIGHT

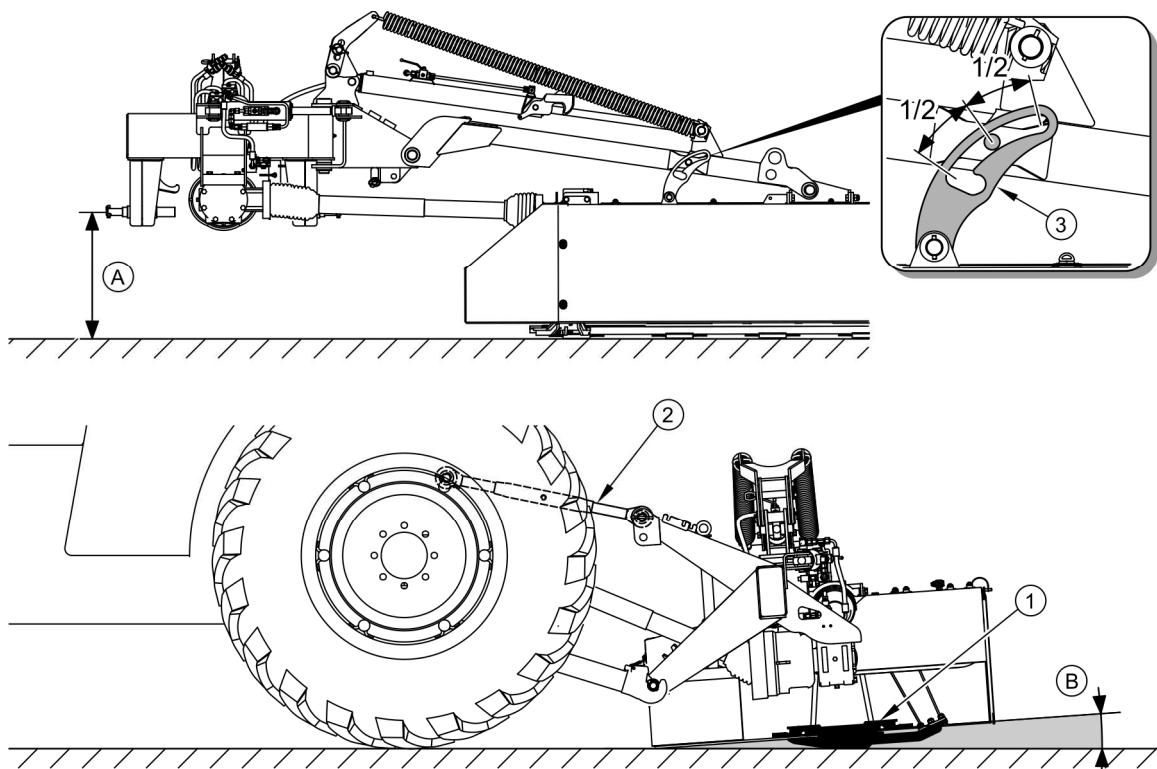

**FIG. 4.7**      **Setting cutting height**

(1) cutter bar; (2) top link; (3) lock; (A) distance of lower link arms from ground - 400mm; (B) cutter bar inclination  $4^{\circ} \div 5^{\circ}$

Once the above is completed adjust the length of the top link (2) so that angle (A) of cutter bar inclination (1) in relation to the ground is from 4° to 5° (figure (4.7)). Cutting height can be set higher by extending the top link (2), or set lower by shortening the top link.

**ATTENTION!**

Optimum angle of inclination of cutter bar to the front is from 4° to 5° . Inclination to the rear causes faster wearing of cutter bar slide surfaces.

**4.5.3 CONNECTING DRIVE SHAFT**

Before connecting the mower it is absolutely necessary to carefully read the Operator's Manual attached by the Manufacturer of the shaft and observe the instructions contained in it. Before connection to the tractor check the technical condition of the shaft guard, the completeness and condition of the protecting chains and the general technical condition of the shaft.

The PTO shaft, which connects PTO of the tractor with the mower's intersecting axis gear is equipped with backstop overload release clutch. When connecting PTO shaft, its end should be terminated with a clutch (1) and connected to the mower gear - figure (4.8).

**DANGER**

Before first use, adjust the length of PTO shaft according to Operator's Manual of PTO shaft recommendations.

Value of transmitted torque for shaft is set in the factory by the Manufacturer and may not be changed by the user. Change of overload protection clutch setting may invalidate the warranty

PTO shaft collecting both intersecting axis gears does not require installation or dismantling.

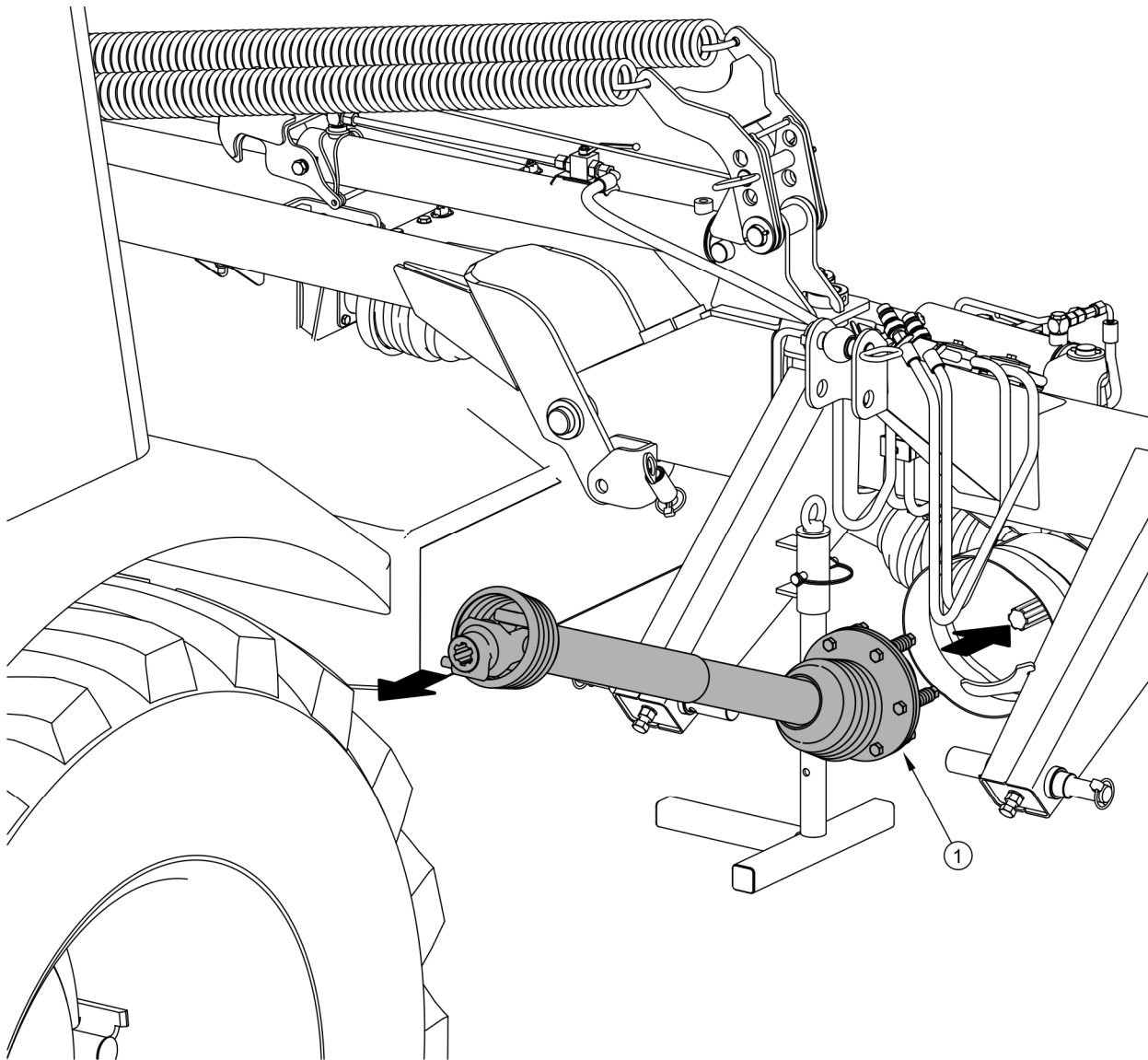
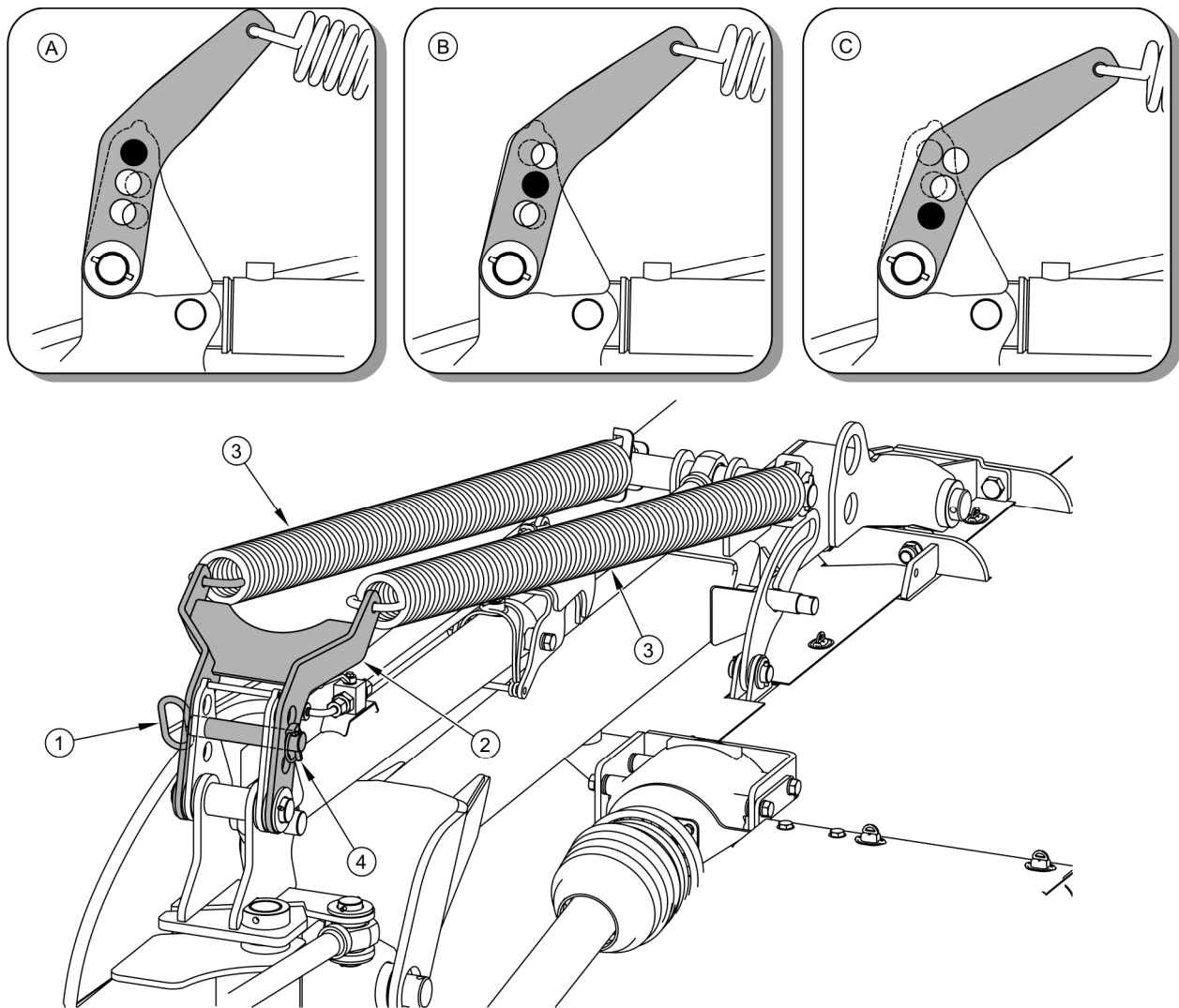

**FIG. 4.8**      **Connecting of PTO shaft**

*(1) PTO shaft backstop overload release clutch*

#### **4.5.4 STAY SPRING ADJUSTMENT**

Stay springs allow for three stage adjustment of cutting unit pressure exerted on the surface. Depending on the type and shape of surface the pressure value may be 70, 80 or 90 kg.



**FIG. 4.9 Stay spring adjustment**

(A) pressure setting for 70kg, (B) pressure setting for 80kg, (3) pressure setting for 90kg, (1) locking pin, (2) spring bracket, (3) stay springs, (4) locking pin cotter pin.

To adjust tension of stay springs (figure (4.9)):

- raise the lifting arms of the cutting unit to reduce spring loading,
- remove securing cotter pin (4) and take out pin (1),
- set bracket accordingly (2), in order to enable insertion of pin (1) in appropriate opening (A, B, or C),
- secure the pin in the chosen position with cotter pin (4).

### 4.5.5 SETTINGS SWATH WIDTH

Two swath guides installed on the PDT260 cutting unit's support frame are used to adjust the swath width - figure (4.10).

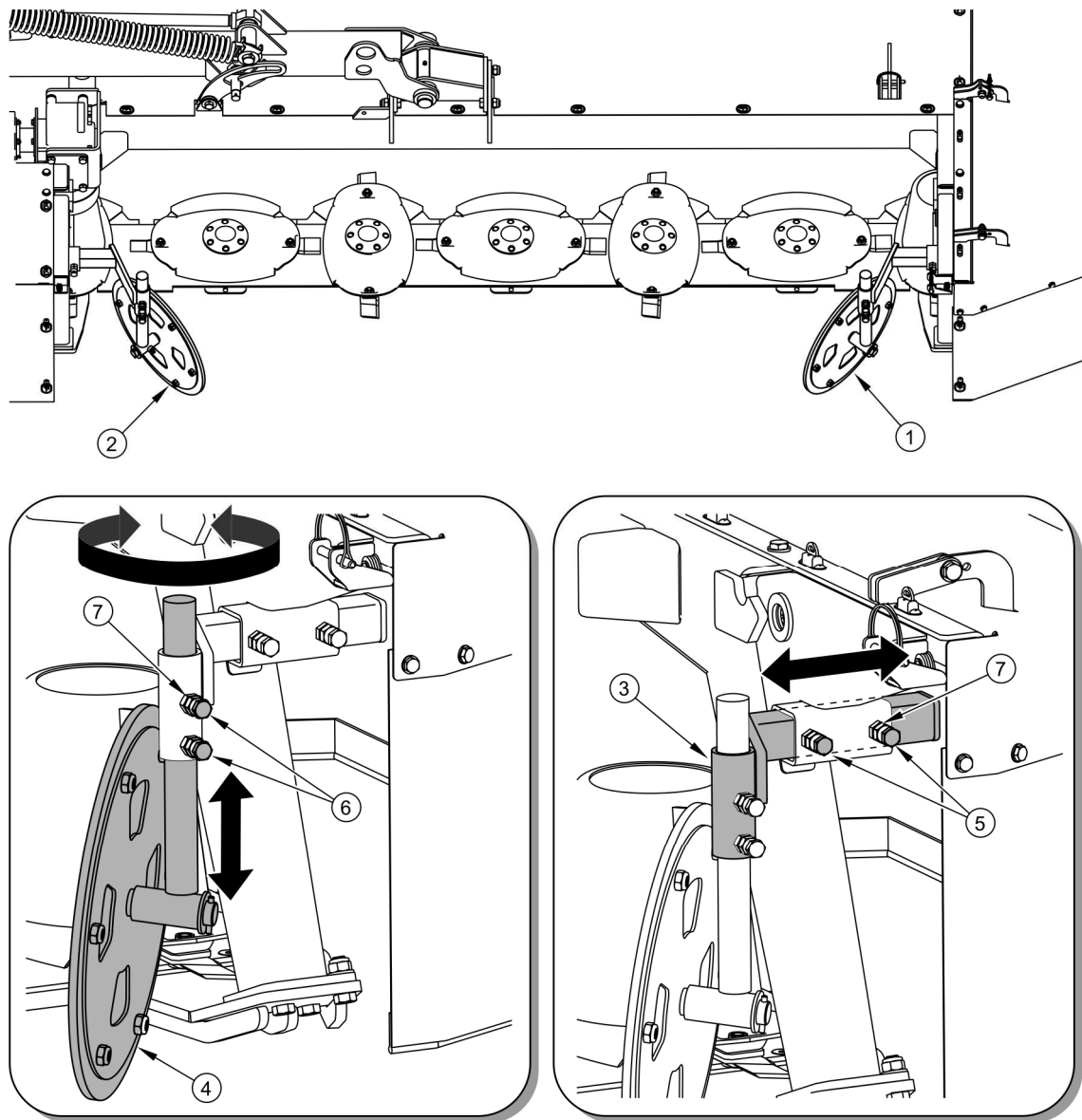

**FIG. 4.10 PDT260 mower swath guide adjustment**

(1) right swath guide, (2) left swath guide, (3) guide arm, (4) disc; (5) arm adjustment bolts; (6) disc adjustment bolts; (7) counter nut

Suitable setting of both swaths guides allows for a stepless adjustment of swath.

Minimal and maximal swath width is given in table (4.2).

**TABLE 4.2 Swath width**

Mower model	PDT260	PDT300	PDT340
Swath width [mm]	1 200 / 1 600	1 200 / 2 000	1 500 / 2 400

To adjust swath guide position:

- Loosen counter nuts (7) and bolts (5),
- Move arm (3) as required, tighten bolts (5) and secure with counter nuts (7),
- Loosen counter nuts (7) and bolts (6),
- Set the height and angle of the disc (4), tighten bolts (6) and secure with counter nuts (7).

Proceed the same way with the opposite swath guide.

Two swath guides installed on the cutting unit's support frame of PDT300 and PDT340 mowers are used to adjust the swath width - figure (4.11). each swath guide has two moving discs.

Suitable setting of both swaths guides allows for a stepless adjustment of swath.

Minimal and maximal swath width is given in table (4.2).

To adjust swath guide position:

- loosen counter nuts and adjustment bolts (8),
- move arm (5) as required, tighten bolts (8) and secure with counter nuts,
- tilt swath guide outwards and remove the chain (6) from the arm,
- rotate the swath guide as needed and put the appropriate chain link (6) in the arm catch (5),
- Unscrew and remove the securing bolt (10),
- pull shaft until you have free access to the spacer rings (7)

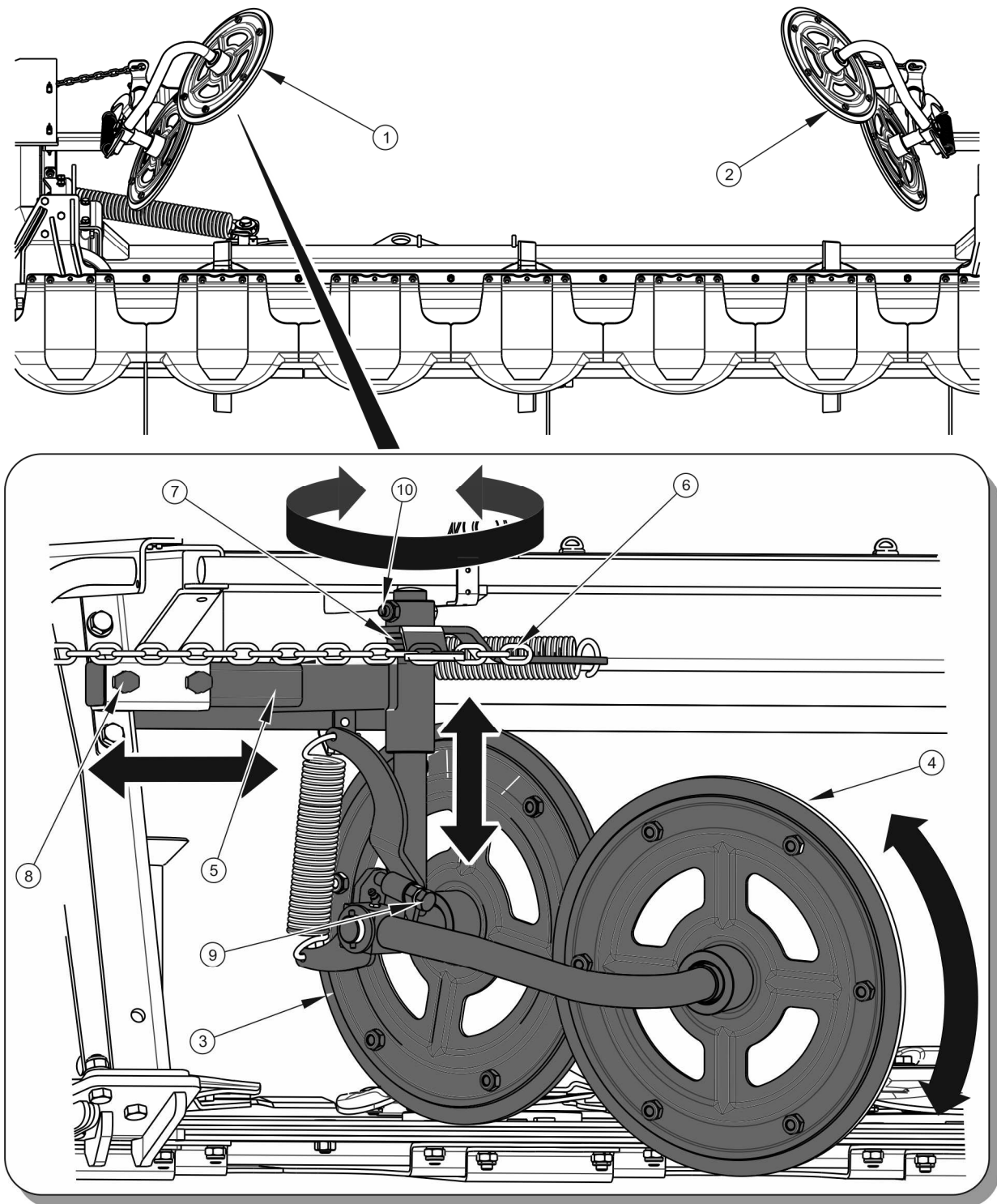

**FIG. 4.11** PDT300 and PDT340 mower swath guide adjustment

(1) left swath guide, (2) right swath guide, (3) disc I, (4) disc II, (5) guide arm, (6) chain, (7) spacer ring, (8) arm adjustment bolts, (9) disc II adjustment bolts, (10) bolt

- adjust the height of the swath guide using the spacer rings (7),
- insert the shaft into the arm (5), insert the bolt (10) and secure it with a nut.

**TIP**

After removing all the spacer rings (7) disc II will operate at the height of the lower edge of the cutter bar.

- loosen adjustment bolts (9) counter nut,
- by screwing or unscrewing the bolt (9) set the correct operating height of disc II (4)
- tighten the counter nut while being careful not to change the position of adjustment bolt (9).

**DANGER**

After completing the adjustments make sure all bolt connections are tight and the range of swath guides motion is correct. The mower may only be started when all guards are in place.

When adjusting swath guides exercise caution as there is a risk of crushing fingers with spring tensioned mechanisms.

#### 4.5.6 SET THE SWATH WIDTH OF PDT260C AND PDT300C MOWER.

Two swath guides installed on the conditioner unit support frame are used to adjust the swath width.

**TABLE 4.3 The swath width for mowers with swath conditioner**

Mower model	PDT260C	PDT300C
Swath width [mm]	1 300 / 1 900	1 700 / 2 350

The swath width can be infinitely varied in the ranges shown in the table (4.3) by adjusting the two swath guides (1). To adjust swath guide position:

- loosen the adjusting screw (3) in the kidney slot of the bracket (4) at the swath guide (1),
- rotate swath guide (1) setting the appropriate swath width, and tighten the adjusting bolt (3) in the kidney slot,

- then adjust the setting of swath blade (2) appropriately to the swath guide (1) so that the mown materials is directed to swath guide. In order to do this:

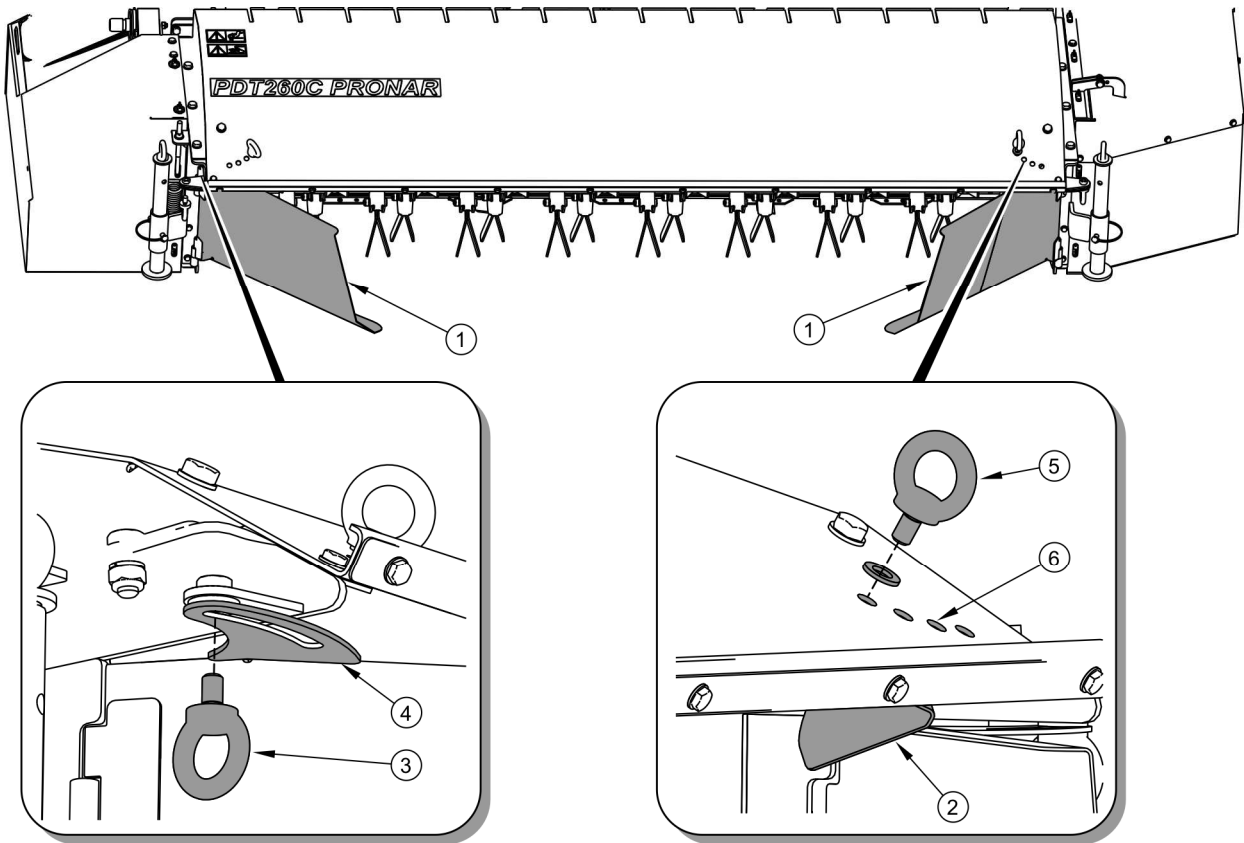

**FIG. 4.12 PDT260C and PDT300C mower swath guide adjustment**

(1) swath guides, (2) swath blade, (3) swath guide adjustment bolt, (4) swath guide bracket with a kidney slot; (5) swath blade adjustment bolt, (6) swath blade adjustment openings.

- unscrew the adjusting bolt (5),
- set swath blade (2) as required so that its opening is in line with the opening (6) in conditioner body
- tighten the adjusting bolt (5) in the selected hole (6).

Proceed the same way with the opposite swath guide and swath blade.

#### **4.5.7 SET THE INTENSITY OF SWATH CONDITIONING FOR THE PDT260C AND PDT300C MOWERS**

Depending on the type and density of the mown material, you can set the intensity of swath conditioning. This is done by the lever (1) on the support frame of the conditioning assembly

connected to the damping fingers. The damping finger must be adjusted so that the mown material does not collect between the cutterbar and conditioning shaft.

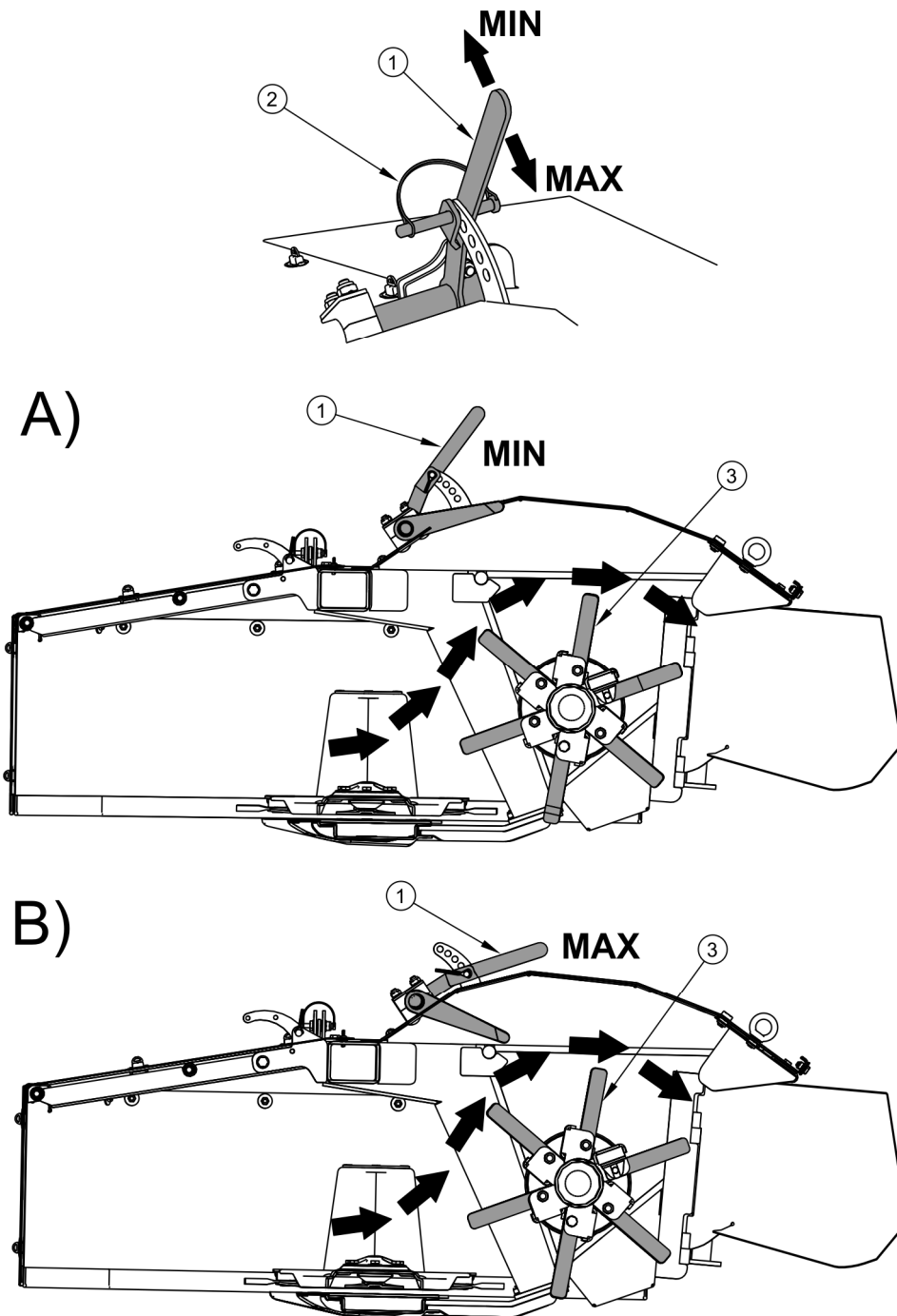

**FIG. 4.13 PDT260C and PDT300C mower swath guide adjustment**

*A- minimum swath conditioning intensity setting; B- maximum swath conditioning intensity setting; (1) swath conditioner adjustment lever, (2) cotter pin, (3) swath conditioner flail blades.*

To adjust swath conditioning intensity:

- release and take out locking cotter pin(2),
- move the adjustment lever (1) down to achieve a greater mown material conditioning intensity (MAX) or up to reduce the conditioning intensity (MIN);
- adjust the lever (1) so that the hole in the lever is in line with a hole in the bracket;
- insert cotter pin in the hole (2) and secure it.

### 4.5.8 MOWING

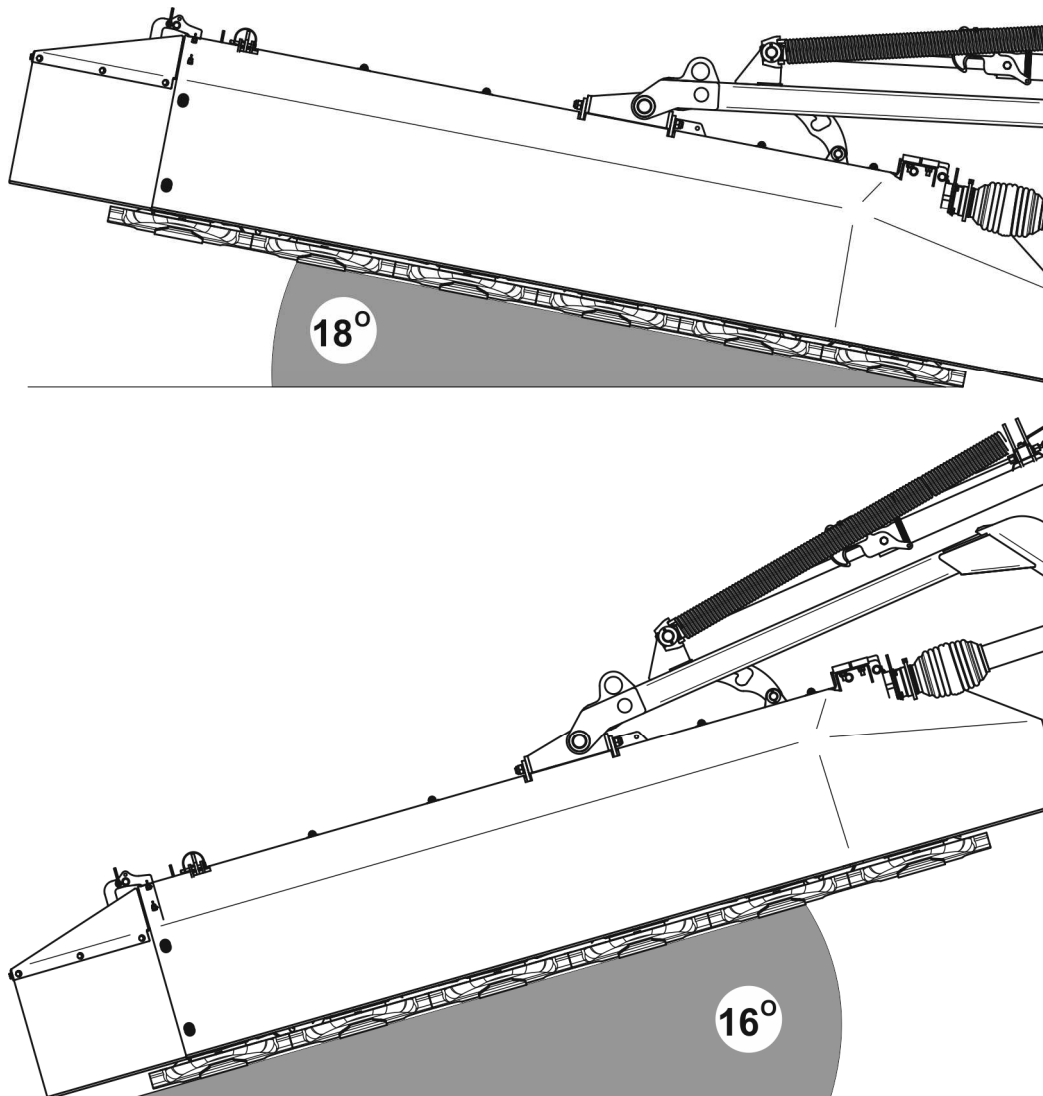

FIG. 4.14 Cutting unit operating range

After setting mower in working position, setting cutter bar and stay springs inclination angle, observe the following procedure: Lower the cutter bar lifting arm until the cutter bar rests on the ground.

Engage the PTO in the tractor at a suitably low speed and then gradually increase the speed until appropriate PTO speed is reached - see table (3.1). During starting the cutting unit generates considerable noise. Noise is reduced when mower is driven into standing crop. During mowing the lever controlling the cutting unit's hydraulic lifting circuit should be set in "floating" position, however the lever controlling arm inclination (hydraulic safety device) should be set in neutral position.

When mowing pay special attention to uneven surface and any large objects lying in the grass. Mowing speed depends on the quantity and quality of mown crop but also on the type of terrain.

## **DANGER**



**The mower may only be started when all guards are in place and the cutting unit is set in working position.**

**Before engaging drive to PTO shaft make sure that there are no bystanders, especially children, near the mower.**

**Other persons should be at a safe distance (minimum of 50 m) from the mower during work because of the danger that objects may be thrown (stones, branches from beneath rotating disks).**

Mowing speed must be reduced if:

- mown ground is uneven,
- crop is laid, or very tall and dense,
- there is a great risk of running into foreign bodies e.g. stones, branches and heaps of soil.

Be especially careful when mowing along ditches, furrows and slopes. When making turns, raise the cutting unit using the lifting cylinder arm without the need to use lifting levers in the tractor. When mowing on hilly terrain or on slopes make turns so that the cutting unit is set up the slope. If during cutting the overload release clutch of the drive shaft is activated, disconnect PTO drive in tractor and check what caused the overload. The overload clutch may be activated because of too low rotation speed of cutting unit.

**ATTENTION!**

Do NOT operate mower while reversing.

**4.5.9 HYDRAULIC SAFETY DEVICE**

The mower is equipped with a hydraulic safety device, which protects the machine against damage resulting from collision with obstacles. When colliding with an obstacle the lifting arm rises and swings backwards. After passing the obstacle the cutting unit returns to the horizontal position and swings forward using the lifting arm inclination hydraulic cylinder. In order to enable action of the hydraulic safety device, both cylinder valves should be set in open position.

**4.6 DISCONNECTING FROM TRACTOR****DANGER**

Reduce pressure prior to disconnecting the hydraulic system.

Before disconnecting mower from the tractor's linkage, lock the lifting arm in parking position using pin (3) and cotter pin (4) (figure 4.15). Do not disconnect mower from tractor before lifting arm is interlocked.

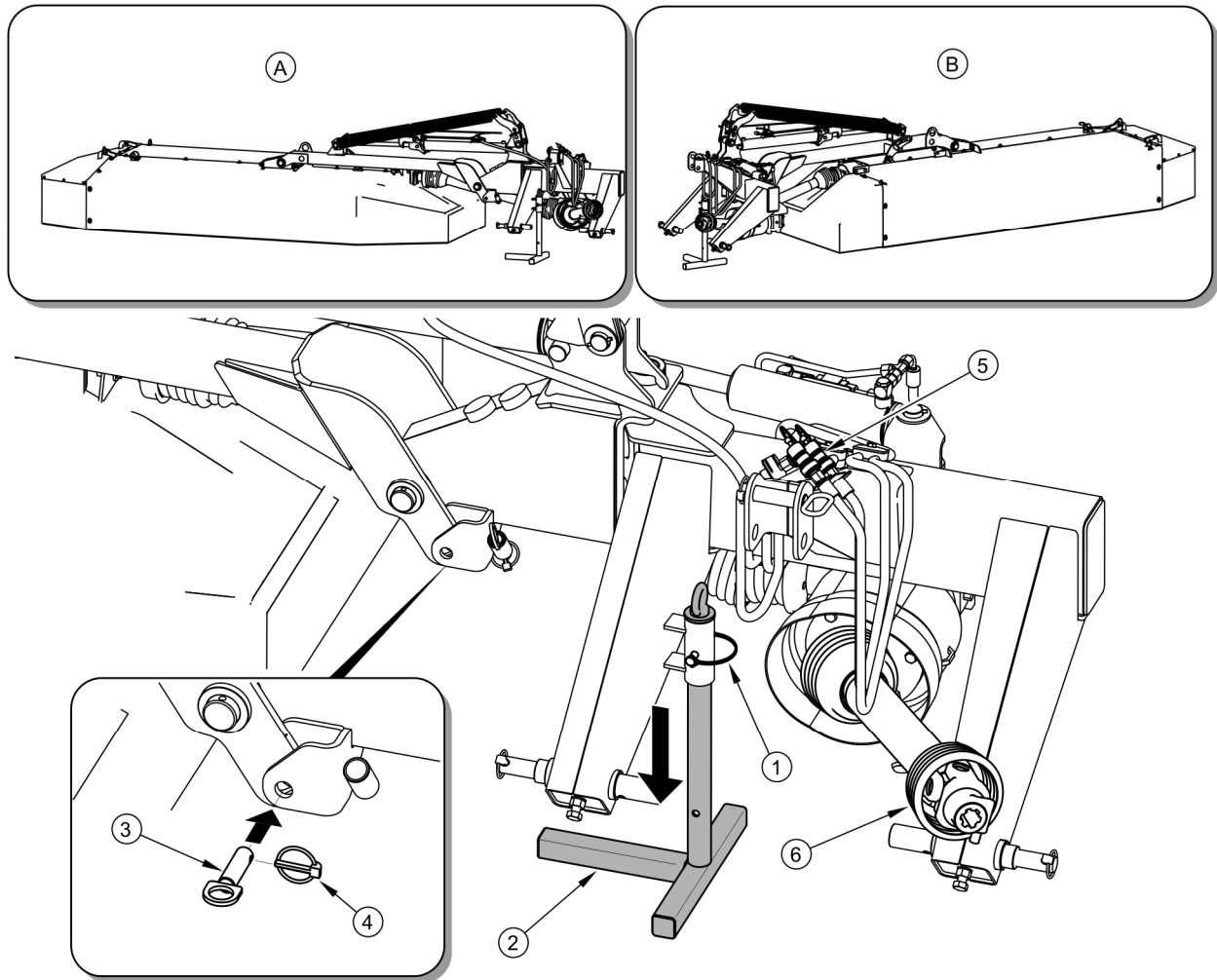

**FIG. 4.15**      **Disconnecting mower from tractor**

*(A),(B) correct positioning of mower disconnected from tractor (1) securing pin; (2) support leg; (3) interlock pin; (4) cotter pin; (5) hydraulic line connectors; (6) PTO shaft*



***SECTION***

**5**

---

**MAINTENANCE**

## 5.1 CHECKING AND REPLACING CUTTING BLADES

### 5.1.1 INSPECTION AND REPLACEMENT OF THE CUTTER BAR BLADES



**DANGER**

During inspection and replacement of blades, switch off tractor engine and remove the key from the ignition and disengage PTO shaft. Cutter bar must rest on the ground.

Use only CE certified blades meeting the requirements of ISO 5718 standard.

Knife inspections must be carried out regularly. Visual inspection involves checking of the knife's blade and mounting. blades should be worn down uniformly. If knife's blade is worn down naturally it can be reversed and reinstalled on the cutting disk (this applies to double edged blades).

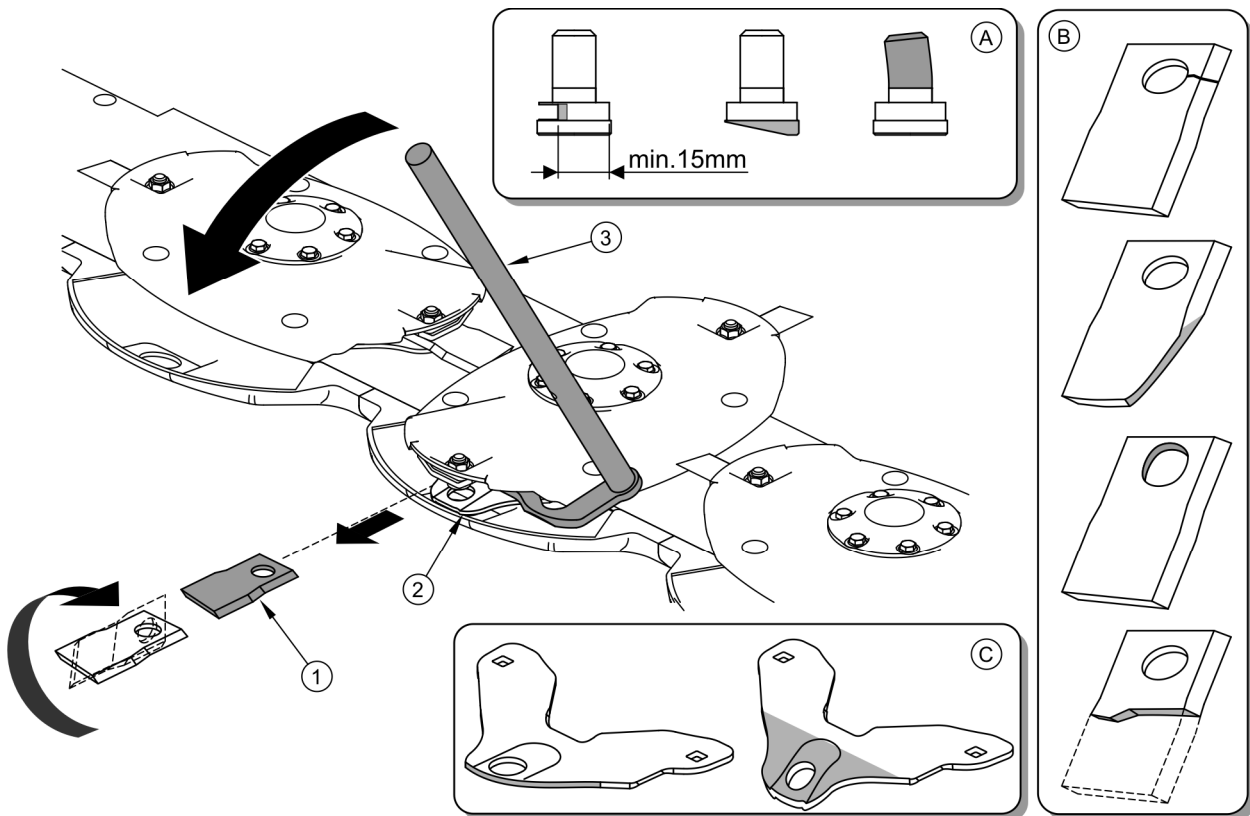

**FIG. 5.1 Replacement of the cutter bar blades**

(1) cutting knife; (2) knife holder; (3) knife changing key; (A) arbor damage example; (B) knife damage example; (C) knife holder damage example

A bent or damaged knife must be replaced with a new one. Cutting blades must be replaced in pairs in order to maintain the balance of the cutting disc. Before proceeding to replace the blades, clean the residue of mown material from the cutter bar.

Use key to change parts (3) placing it between knife holder (2) and cutting disc, next press on key (3) till the moment that it is possible to take out the (1). When changing blades check the condition of the arbor securing the knife to the cutting disk and also the knife holder. An excessively worn or damaged arbor or knife holder should be replaced with a new part. Tighten arbor nuts with torque of 120 Nm.



### ATTENTION!

Missing knife or its fragment will cause imbalance and excessive cutting disk vibration and may damage the cutter bar.



### TIP

Damaged or worn blades must be changed in pairs in order to maintain balance of cutting disc.

**TABLE 5.1 CUTTING KNIFE SPECIFICATION**

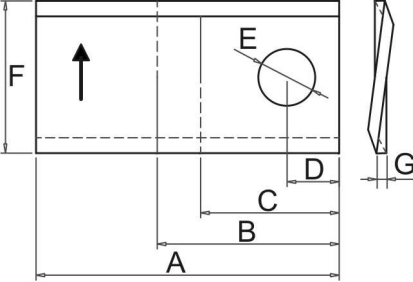
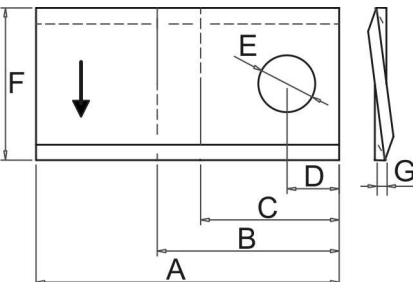
MARKING KNIFE	FIGURE	DIMENSIONS [mm]						
		A	B	C	D	E	F	G
BRZW 120/49/4 P (RIGHT)		120	57	42	20	21	49	4
BRZW 120/49/4 L (LEFT)		120	57	42	20	21	49	4

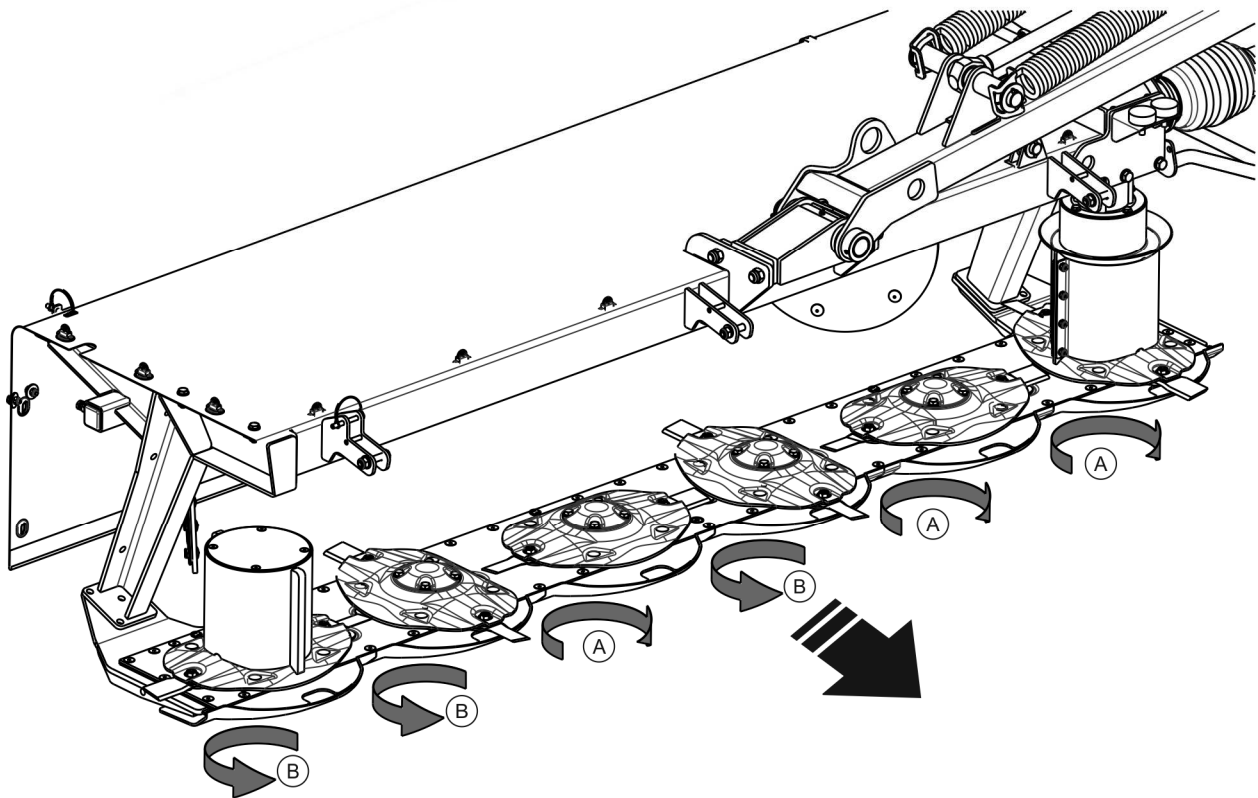

**FIG. 5.2 Knife types depending on cutting disc rotation direction**

*(A) right blades; (B) left blades*

Due to different cutting disc rotation direction, cutter bar (figure 5.2) is equipped with the right blades (A) and left blades (B). Rotation direction is indicated on the knife.



**ATTENTION!**

Each time a knife hits an obstacle such as a stone or a branch, its technical condition must be inspected.

**5.1.2 INSPECTION AND REPLACEMENT SWATH CONDITIONER FLAIL BLADES (PDT260C, PDT300C)**

Regularly inspect beater fingers. Visually inspect beater fingers, their mountings and rubber blocks. Worn rubber blocks, distorted or broken fingers should be replaced. Fingers should be replaced in pairs to maintain balance.

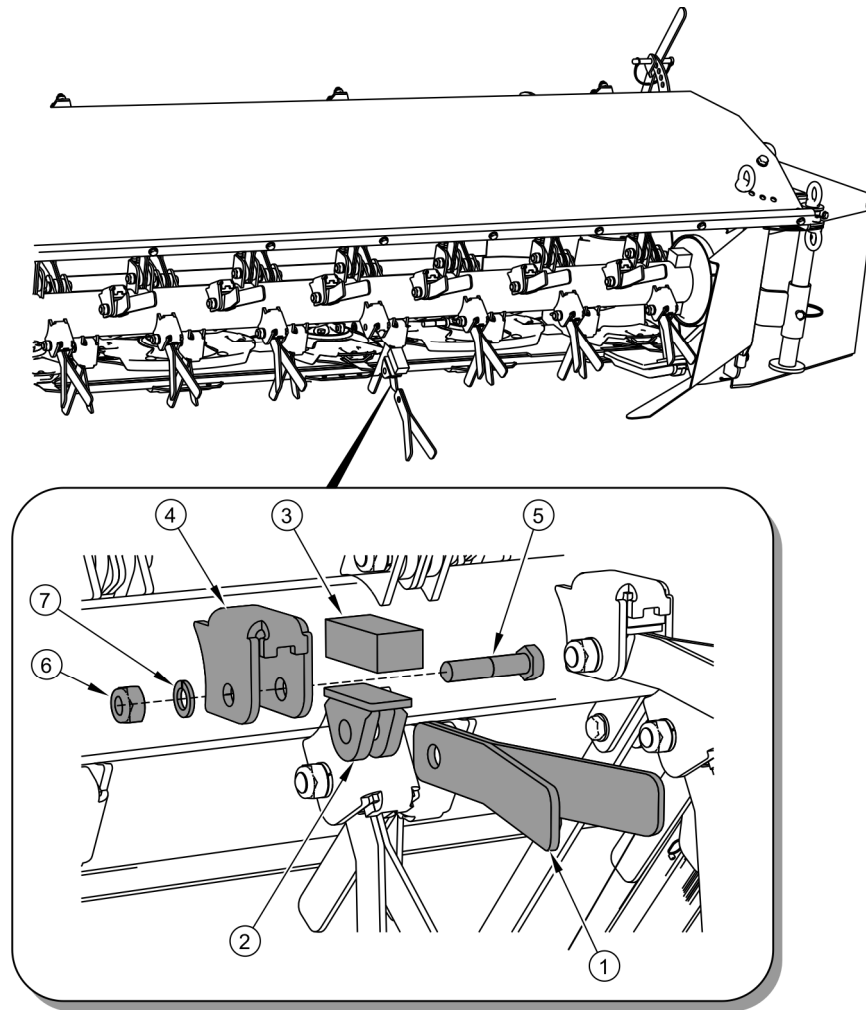

**FIG. 5.3 Check oil level in cutter bar**

(1) flail blades, (2) blade lock, (3) rubber block, (4) blade mount (5) M12x55 kl.8.8 mounting bolt; (6) M12 kl.8.8 self-locking nut ; (7) spring washer.

To replace the flail blades:

- unscrew the M12 self-locking nut (6)
- Remove the M12x55 fixing bolt (5)
- remove a pair of flail blades (1) from the lock (2).

When replacing the flail blades pay attention to the condition of the fixing bolt (5) and rubber block (3). Excessively worn or damaged bolt or rubber block should be replaced. Installation of the new flail blades should be performed in reverse order. Nut (6) of the fixing bolt must be tightened so that the flail blades (1) can move freely in the blade lock (2).



**DANGER**

During inspection and replacement of beater fingers, switch off tractor engine and remove the key from the ignition and disengage PTO shaft. Rest conditioning assembly on the ground on parking stands.

## 5.2 CUTTERBAR MAINTENANCE

Cutting unit maintenance involves periodical checking of oil level and changing of oil in cutter bar.

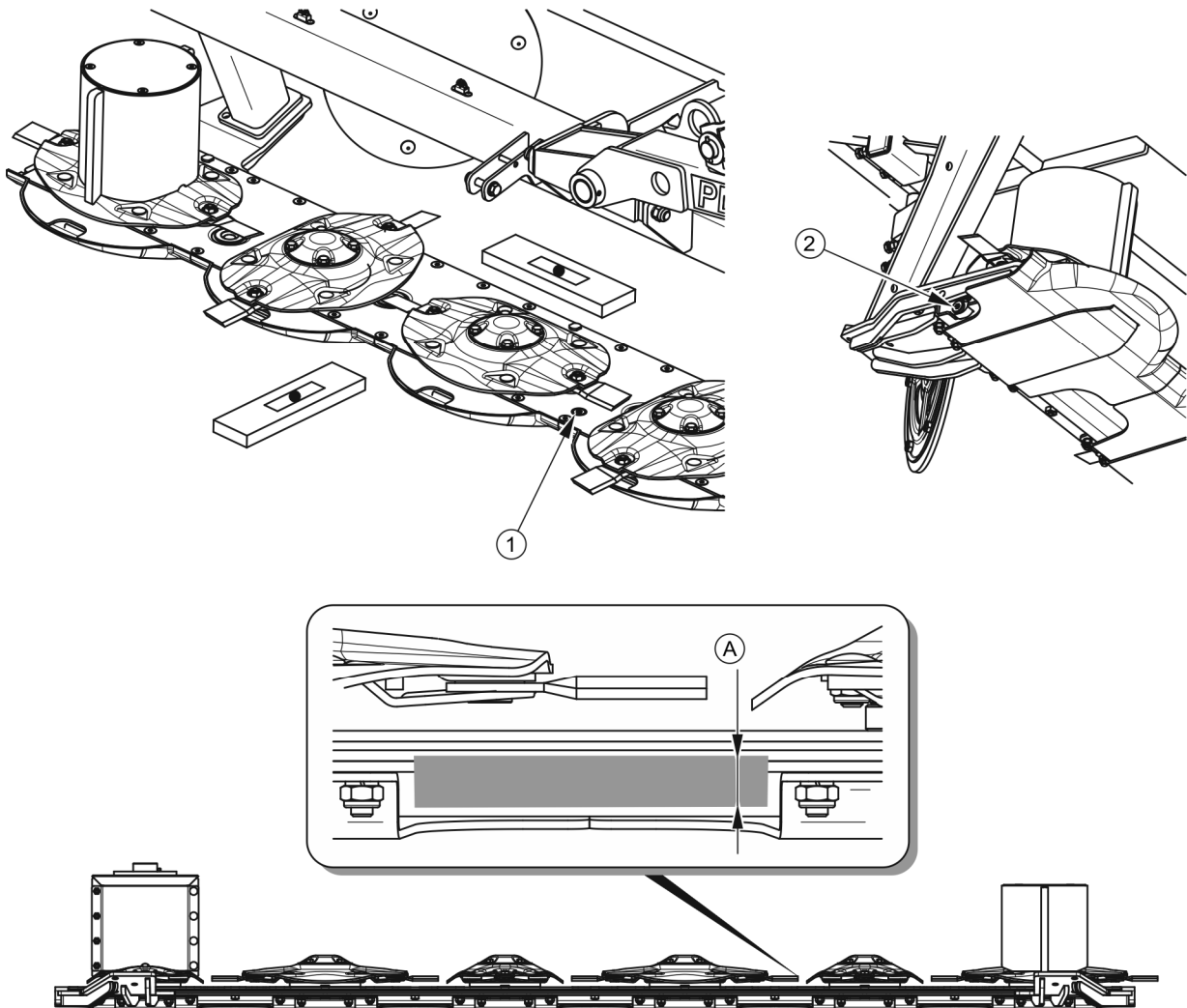

**FIG. 5.4** Check oil level in cutter bar

(1) inlet cap; (2) drain plug; (A) correct oil level 4 ÷ 5mm from the cutter bar bottom

Correct oil level (A) with cutter bar in horizontal position is 4 ÷ 5mm from the cutter bar bottom. To check oil level remove inlet cap (1) located between the third and fourth disk - figure (5.4). When oil is cold wait approximately 15 minutes before checking the oil level. Just check the oil level on a level cutter bar.



**Check oil level in cutter bar each time before beginning work.**

First oil change should be made after 50 hours mower operation and then, after each 500 hours of operation or at least once in the season, whichever occurs first. Cutter bar is filled with SAE90EP (80W90GL5) gear oil. It is best to change oil immediately after completing work when cutter bar is still hot and impurities are suspended in oil.

**TABLE 5.2 Oil quantity**

Mower model	PDT260	PDT300	PDT340
Oil quantity [l]	1.75	2.1	2.4

In order to change oil in cutter bar:

- unscrew filler plug (1) – figure (5.4),
- raise cutterbar,
- unscrew drain plug (2) and drain oil to previously prepared basin,
- tighten drain plug (2),
- Position cutting unit horizontally and pour the required quantity of oil through the inlet (1),



**Oil in cutter bar must be changed after the first 50 hours of work. The next oil change should be made after 500 hours of work or once a year, whichever occurs first.**

If a leak is noticed, carefully inspect seals and check oil level. Mower operation with low oil level in cutter bar may cause lasting damage. Repairs of cutter bar during warranty period (except knife replacement) may only be performed at authorised mechanical workshops.

To ensure proper operation of the mower, regularly clean and lubricate drive disc articulated shaft (1) - figure (5.5). Failure to regularly clean and lubricate the articulated shaft (2) can lead to seizing of the connection and machine damage.

#### Required service actions

- unscrew nuts (5) and take out bolts (4),
- Remove both covers (3),
- Clean and lubricate the articulated shaft (2),
- Clean the inner surfaces of the cover,
- replace the covers and insert the bolts. The secure the connection with washers (6) and nuts (5).

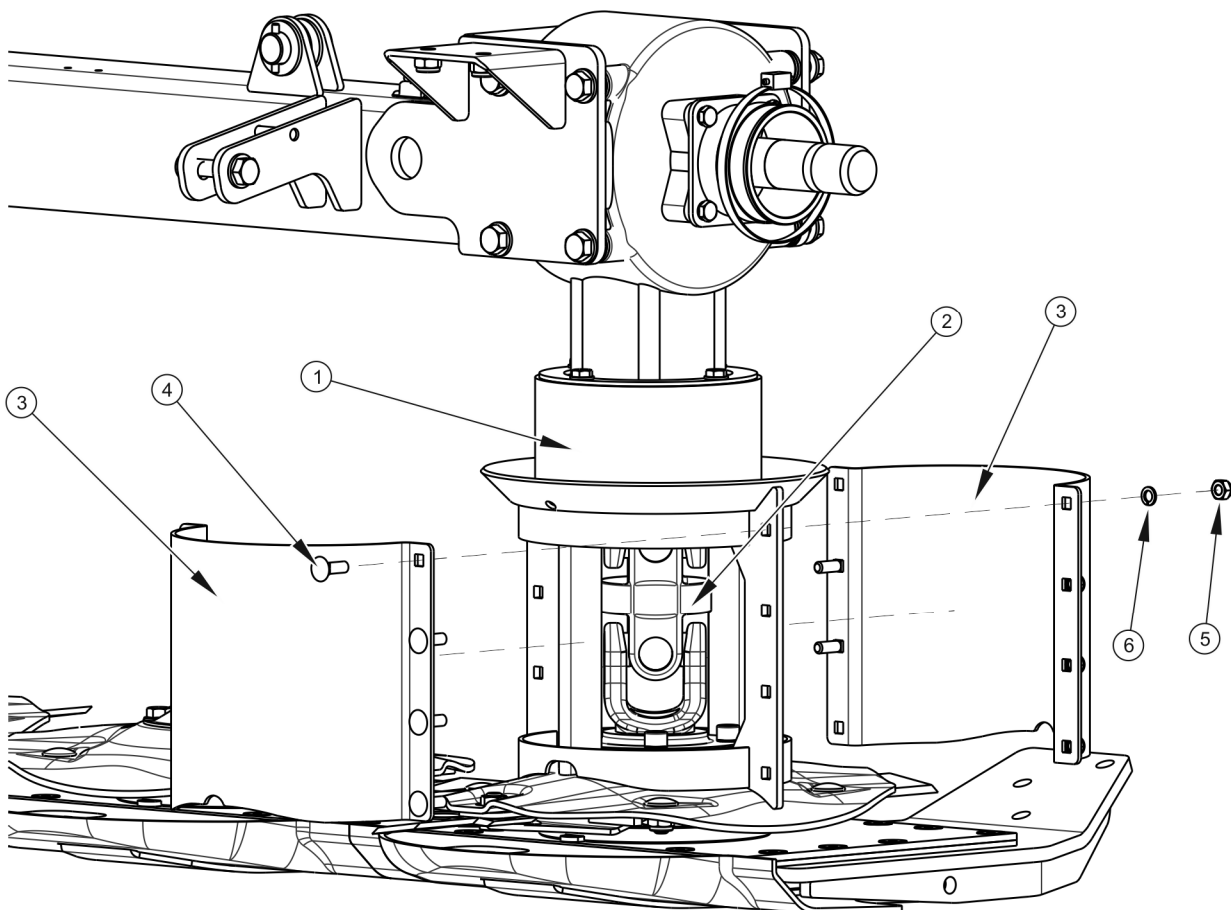

**FIG. 5.5** Clean and lubricate the drive disk

(1) drive disc, (2) articulated shaft, (3) cover, (4) bolt, (5) nut (6) washer

**ATTENTION!**

The dirt accumulated inside the drive disc such as grass clippings, sand, etc. can lead to seizure of the articulated shaft. Shaft seizure can damage the mower transmission.



Carry out maintenance of the drive disc at least twice during the grass mowing season and always after the season.

## 5.3 MAINTENANCE OF DRIVE UNIT

Drive system maintenance involves periodical checking of oil level and changing of oil in mower's intersecting axis gears.

**DANGER**

Do NOT perform service or repair work under raised and unsupported machine.



Check oil level in intersecting axis gears daily.

To check the oil level in intersecting axis gears:

- set mower level horizontally,
- unscrew inspection plug (2),
- oil level should reach the lower edge of the inspection plug opening (2),
- if necessary, supplement oil through inlet opening (1) to the required level.

**DANGER**

When checking oil level and changing oil, use appropriate personal protection equipment i.e. protective clothing, safety shoes, gloves, safety goggles. Avoid contact of skin with oil.

 Oil in both intersecting axis gears must be changed after the first 50 hours of work. The next oil change should be made after 500 hours of work or once a year, whichever occurs first.

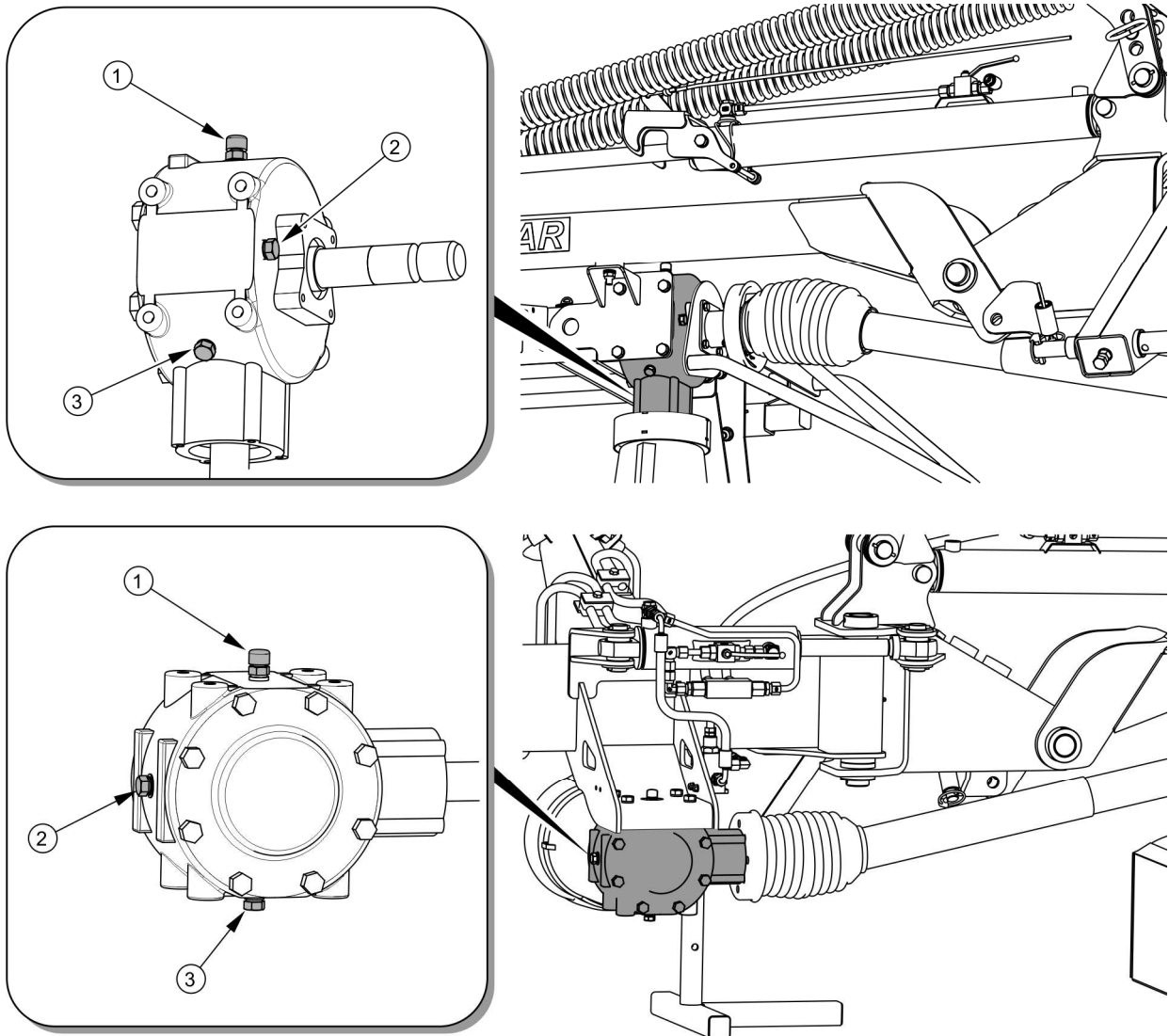

**FIG. 5.6 Changing oil in intersecting axis gears**

*(1) filler plug, (2) inspection plug, (3) drain plug*

In the same manner check oil level in the other gear.

To change oil in intersecting axis gear:

- set mower on a hard and level surface
- unscrew filler plug (1) and inspection plug (2),
- unscrew drain plug (3) and drain oil to previously prepared basin,

- if oil Manufacturer recommends flushing transmission, that operation should be performed according to the guidelines of the oil Manufacturer (guidelines may be detailed on packaging),
- tighten drain plug (3),
- add oil until oil flows out of inspection opening (2),
- tighten inlet and inspection plugs.

Used oil should be taken to the appropriate facility dealing with the re-use of this type of waste.

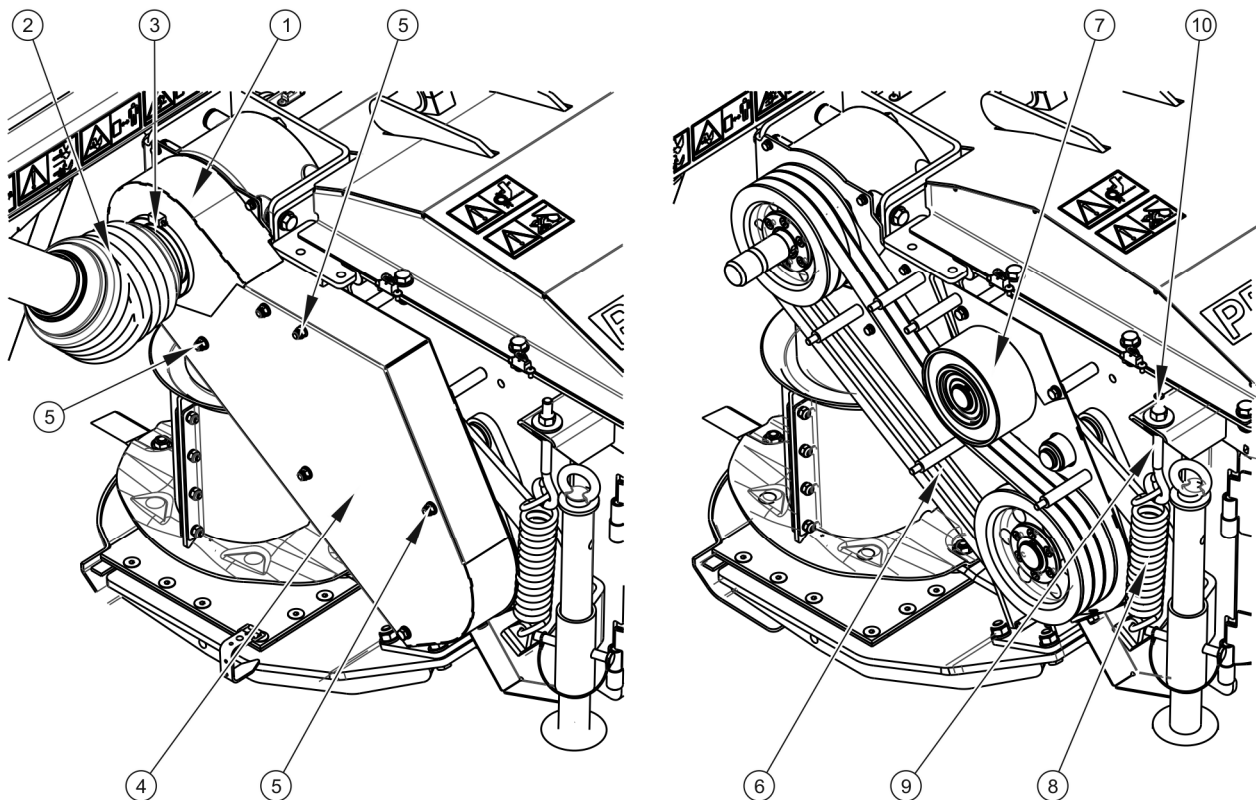

**FIG. 5.7 Voltage regulation belt drive mower conditioners**

(1) first transmission casing, (2) drive shaft, (3) band clamp, (4) second transmission casing, (5) nuts, (6) transmission belt, (7) tensioner, ( 8) tension spring, (9) tensioner bolt, (10) adjustment nut; (11) locknut.

To lubricate intersecting axis gears use SAE90EP (80W90GL5) gear oil in quantity of 1.1 litre for each gear.

If a leak is noticed, carefully inspect seals and check oil level. Transmission operation with insufficient oil may cause permanent damage of the mechanism.

Repair of transmission during warranty period may only be performed at authorised mechanical workshops.

In addition to periodic inspection of intersecting axis gears, swath conditioner mowers also require the monitoring of belt tension in swath conditioner belt drive.



### **DANGER**

**Before proceeding to check or adjust drive transmission belt set first turn off tractor engine and remove key from ignition.**

Belt tension can be adjusted using the adjustment nut (10) screw (10) of the tensioner bolt (9). To do this, unscrew the locknut (11) and tighten the adjusting nut (10) on the bolt (9) to the point where the tensioner spring will be at a minimum tension. The deflection of the belt (1) measured at the mid point between the pulley on the intersecting axis gear and pulley of the conditioner shaft should not exceed 10 mm under the pressure of 7.5 daN (kg). If tension cannot be adjusted, replace belts for new ones. There are three SPB 1525 belts in the transmission system. To replace the V-belts, loosen the tensioner spring (7) with the adjustment bolt (10) and remove the belts from the pulleys.

Check the swath conditioner unit belt tension after 2 hours of use. If necessary, tighten the belts according to the above guidelines.

## **5.4 HYDRAULIC SYSTEM OPERATION**



### **DANGER**

**Before commencing whatever work on hydraulic system reduce the pressure in the system.**

**During work on hydraulic systems use the appropriate personal protection equipment i.e. protective clothing, footwear, gloves and eye protection. Avoid contact of skin with oil.**

Always adhere to the principle that the oil in the mower hydraulic system and in the tractor hydraulic system are of the same type. Application of different types of oil is not permitted. In a new mower, the hydraulic system is filled with HL32 hydraulic oil.



### ATTENTION!

The condition of hydraulic system should be inspected regularly while using the machine.

The hydraulic system should be completely tight sealed. Inspect the seals when hydraulic ram cylinders are completely extended. In the event of confirmation of oil on hydraulic ram cylinder bodies ascertain origin of leak. Minimum leaks are permissible with symptoms of "sweating", however in the event of noticing leaks in the form of "droplets" stop using the machine until faults are remedied.

In the event of confirmation of an oil leak on hydraulic line connections, tighten connections, and if this does not remedy faults then change line or connection elements. Change of sub-assemblies is equally required in each instance of mechanical damage.

**TABLE 5.3 HL32 HYDRAULIC OIL CHARACTERISTICS**

ITEM	NAME	VALUE
1	ISO 3448VG viscosity classification	32
2	Kinematic viscosity at 40°C	28.8 ÷ 35.2 mm <sup>2</sup> /s
3	ISO 6743/99 quality classification	HL
4	DIN 51502 quality classification	HL
5	Flash-point	above 210°C

Because of its composition the oil applied is not classified as a dangerous substance, however long-term action on the skin or eyes may cause irritation. In the event of contact of oil with skin wash the place of contact with water and soap. Do NOT apply organic solvents (petrol, kerosene). Contaminated clothing should be changed to prevent access of oil to skin. In the event of contact of oil with eye, rinse with large quantity of water and in the event of the occurrence of irritation consult a doctor. Hydraulic oil in normal conditions is not harmful to the respiratory tract. A hazard only occurs when oil is strongly atomised (oil vapour), or in the case of fire during which toxic compounds may be released. Oil fires should be quenched

with the use of carbon dioxide (CO<sub>2</sub>), foam or extinguisher steam. Do NOT use water for fire extinguishing.

Spilt oil should be immediately collected and placed in marked tight container. Used oil should be taken to the appropriate facility dealing with the re-use of this type of waste.



**Flexible hydraulic lines should be replaced after 4 years of use.**

## 5.5 STORAGE

After finishing work, mower should be thoroughly cleaned and washed with water jet. While washing do not direct a strong water or steam jet at information and warning decals, bearings or hydraulic lines. Nozzle of pressure or steam washer should be kept at a distance of not less than 30 cm from cleaned surface.

After cleaning, inspect the whole machine, inspect technical condition of individual elements. Used or damaged elements should be repaired or replaced.

In the event of damage to the paint coat, clean rust and dust from damaged area, degrease and then paint with undercoat and after it is dry paint with surface coat paint retaining colour uniformity and even thickness of protective coating. Until the time of touch-up painting, the damaged place may be covered with a thin layer of grease or anticorrosion preparation. Mower should be kept in closed or roofed building.

If the mower shall not be used for a long period of time, protect it against adverse weather conditions. Lubricate mower according to the instructions provided. In the event of prolonged work stoppage, it is essential to lubricate all elements regardless of the period of the last lubrication process. Additionally before the winter period apply grease to hitching system pins.

## 5.6 LUBRICATION

Machine lubrication should be performed with the aid of a manually or foot operated grease gun, filled with generally available permanent grease. Before commencing lubrication insofar

as is possible remove old grease and other contamination. Remove and wipe off excess oil or grease.



When using the machine the user is obliged to observe lubrication instructions according to attached schedule. Excess lubrication substance causes depositing additional contaminants in places requiring lubrication, therefore it is essential to keep individual machine elements clean.

Oil gear in cutter bar in accordance with recommendations given in section 5.2 *CUTTER BAR MAINTENANCE*. For detailed instructions on how to change oil in intersecting axis gears please refer to section 5.3 *DRIVE SYSTEM MAINTENANCE*. Lubrication points are shown on figure (5.8) and detailed in table (5.4) *LUBRICATION POINTS AND LUBRICATION FREQUENCY*.

**TABLE 5.4 Lubrication points and lubrication frequency**

ITEM	LUBRICATION POINT	NUMBER OF LUBRICATION POINTS	TYPE OF GREASE	FREQUENCY
1	Lifting pin of lifting arm	1	A	20h
2	Tipping pin of lifting arm	1	A	20h
3	Cutting unit pin	1	A	20h
4	Left and right swath guide disk axis	2	A	20h
5	Tilting arm cylinder ram eye	1	A	50h
6	Tilting arm cylinder ram eye	1	A	50h
7	Lifting arm cylinder ram eye	1	A	50h

ITEM	LUBRICATION POINT	NUMBER OF LUBRICATION POINTS	TYPE OF GREASE	FREQUENCY
8	Lifting arm cylinder eye	1	A	50h
9	Cutter bar	1	B	500h
10	Intersecting axis gear I	1	B	500h
11	Intersecting axis gear II	2	B	500h
12	Surface of multi-splined drive shaft	1	A	20h
13	Cutterbar double articulated connection joint	2	A	50h
14	PTO shafts *	*	*	*
15	Swath conditioner shaft bearings (PDT260C, PDT300C)	2	A	50h

Marking description in Item column (table 5.4) conforms with numbering shown (figure 5.8)

\* For detailed information on maintenance please refer to maintenance instructions attached to the shaft.

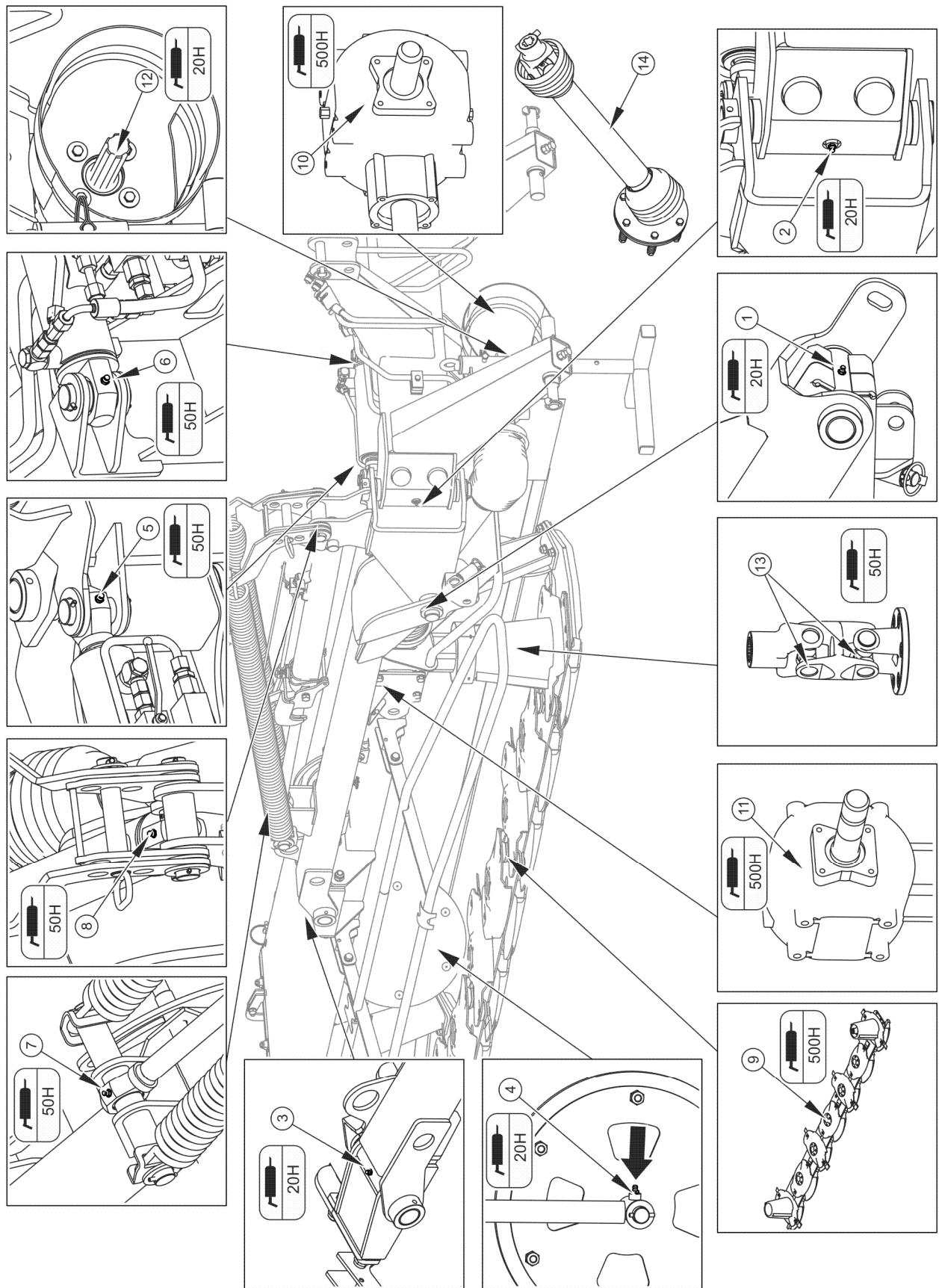



FIG. 5.8 Lubrication points on the mower

**TABLE 5.5 Recommended lubricants**

LISTED ON TAB. (5.4)	DESCRIPTION
A	machine general-purpose grease (lithium, alkaline),
B	standard machine oil,

Empty grease or oil containers should be disposed of according to the recommendations of the lubricant Manufacturer.



During mower use the user is obliged to observe lubrication instructions according to attached lubrication schedule.

## 5.7 CONSUMABLES

### 5.7.1 LUBRICANTS

For mower lubrication the application of general purpose machine greases is recommended, which contain anticorrosion additive and have significant resistance to being washed away by water.

Before starting to use greases acquaint oneself with the content off the information leaflet for the chosen product. Particularly relevant are safety rules and handling procedures for given lubricant product and waste utilisation (used containers, contaminated rags etc.). Information leaflet (material safety data sheet) should be kept together with grease.

## 5.8 TIGHTENING TORQUE FOR NUT AND BOLT CONNECTIONS

Unless other tightening parameters are given, during maintenance repair work apply appropriate torque to tightening nut and bolt connections. Recommended tightening torque of most frequently applied nut and bolt connections are given in table below. Given values apply to non-lubricated steel bolts.

**TABLE 5.6** Tightening torque for nut and bolt connections

THREAD METRIC	5.8 <sup>(1)</sup>	8.8 <sup>(1)</sup>	10.9 <sup>(1)</sup>
	Md [Nm]		
M8	18	24	34
M10	37	49	72
M12	64	85	125
M14	100	135	200
M16	160	210	310
M20	300	425	610
M24	530	730	1,050
M27	820	1,150	1,650
M30	1050	1,450	2,100
M32	1050	1,450	2,100

<sup>(1)</sup> – resistance class according to DIN ISO 898 standard

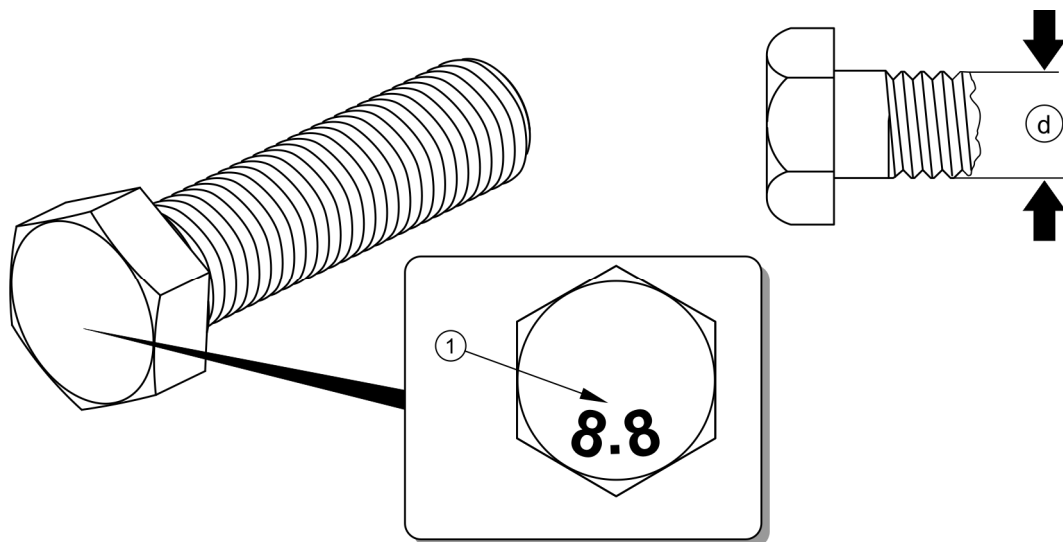
**FIG. 5.9** Bolt with metric thread

(1) resistance class, (d) thread diameter



**ATTENTION!**

Should it be necessary to change individual parts, use only original parts or those indicated by the Manufacturer. Non-adherence to these requirements may put the user and other people's health and life at risk, and also damage the machine.

## 5.9 TROUBLESHOOTING

**TABLE 5.7 TROUBLESHOOTING**

TYPE OF FAULT	CAUSE	REMEDY
Mower arm cannot be lifted or lowered	Lifting arm interlocked	Remove blocking pin
	Incorrect connection or damaged quick coupler	Check quick coupler and manner of connection
	Blocked cylinder lock	To unblock lock pull cable
	Unreliable tractor hydraulic system	Check condition of tractor hydraulic system
Stubble is uneven	Cutter bar is excessively load relieved	Set load relief spring appropriately
	Tractor PTO rotation speed too low	Maintain correct, constant PTO speed
	Worn cutting blades	Turn blades onto the second side or replace
	Incorrect cutting angle	Set appropriate cutterbar inclination by adjustment of top link
Excessive vibration during work	Damaged or missing knife	Check knives, if necessary replace
	Damaged PTO shaft	Check shafts, if necessary replace
	Damaged cutterbar bearing	Repair at authorised service point
Excessive heating of intersecting axis gear or cutterbar	Incorrect oil level	Check oil level.
	Damaged bearing	Repair at authorised service point

Hydraulic safety device does not work	Cylinder valve closed	Set cylinder interlock valve lever in open position
Mower drive stops during cutting	Shaft overload clutch activated as a result of cutting discs being blocked	Disconnect power from mower; remove collected grass or foreign body from cutting unit
	Damaged cog in cutterbar	Repair at authorised service point
	Damaged intersecting axis gear	Repair at authorised service point



# NOTES

A series of horizontal dotted lines for writing notes.



